

Agricultural Machinery

Practical

2nd Stage

Lecturers:

Mr. Abdullah F. Younis

Mr. Alaa A. Sahib

2019 - 2020

Lecture 1

Machinery Safety

Is an aspect of occupational safety and health in the agricultural work place. It specifically addresses the health and safety of farmers, farm workers and their families.

Machines are designed to use power, torque, motion, and energy to perform work. They may be powered by power takeoff drivelines, hydraulic oil pressure, electrical motors, internal combustion engines, or ground traction. Regardless of how machines are powered, they present a number of hazards to those working around them.



Important points in machinery Safety

1. Never operate farm machinery while under the influence of drugs or alcohol.



2. Before using a piece of farm machinery, the operator must read and understand the user's manual for that equipment.

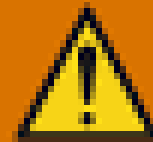

WARNING

Read and fully understand operator's manual before using this machine.

Failure to follow operating instructions could result in death or serious injury.



3. The operator must receive training course on the safe operation of that equipment by a competent person.



4. Protective clothing should be worn during the operation of farm machinery.



shutterstock.com • 347774981



5. The majority of farm machinery was designed to carry a single operator. Passengers should not be carried on tractors, combines, sprayers, etc.,



6. Safety guards should always be in place when operating any piece of machinery. This includes power take-off (PTO) master shields, PTO driveline shields, auger throat shields, belt shields, chain guards, etc.



7. Equipment being refueled should have its engine turned off before refueling.

Refuel equipment safely.



- Refuel far from buildings.
- Make sure motors are cool and engines turned off.



8 . All tractors should be equipped with Roll-Over Protective Structures (ROPS), and A seat belt should be worn when operating .

What's a ROPS?

*ROPS - Rollover
Protective Structure*

*During an overturn
a ROPS and seat belt
hold the operator in
a "frame of safety."*

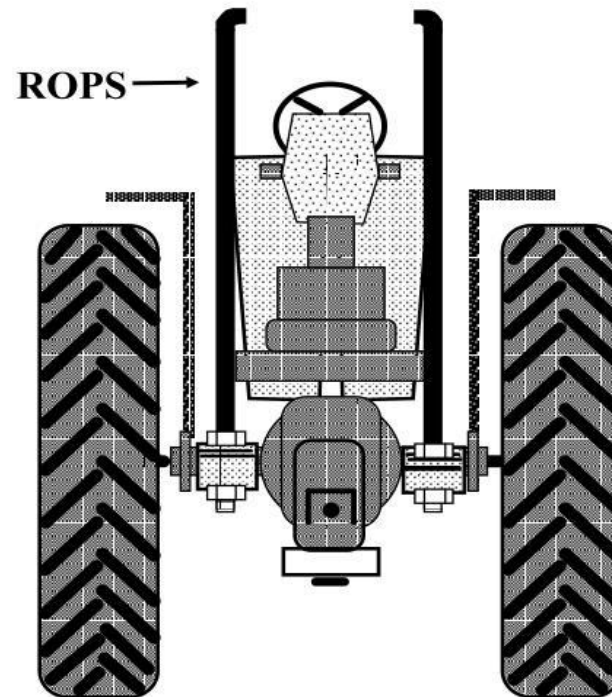

9 . All farm equipment traveling on any roadway should be equipped with an approved Slow Moving Vehicle (SMV) emblem.



SHARING the ROAD with SLOW-MOVING VEHICLES



10 . When traveling on public roadways, obey all traffic laws.



11 . All implements and attachments should Only be used in the proper manner for which they were designed.



Disc Plough



Disc Harrow



Rotary Tiller



Share Plough



Ridger



Potato Planter



Potato Harvester



Thresher



Cultivator



12. Many tractor accidents involve excessive speed. Drive at a speed appropriate for:

- the job you are doing
- the terrain over which you are traveling
- the piece(s) of equipment you are using

Remember to slow down whenever making turns.

