



Electrical Measurements Lab.

2nd Year Physics Department

(Second Semester)

2023-2024

Prepared by:

Dr. Goran Muhammad Khalil

Dr. Herish Ahmed Khizir

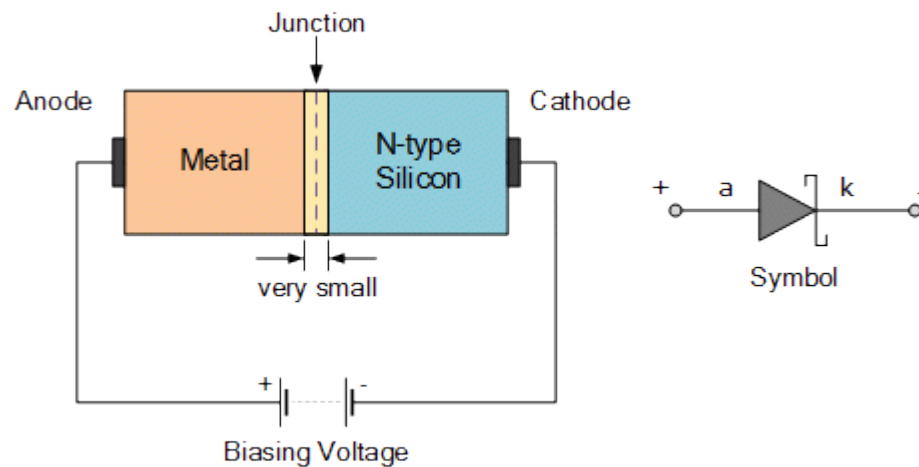

Experiment No: 1

Diode Characteristics

Objective: To study and verify the functionality of:

- a) **PN junction diode in forward bias**
- b) **Point-Contact diode in reverse bias**

Biasing of PN junction Diode:

Forward bias operation

The P-N junction supports unidirectional current flow. If (+ve) terminal of the input supply is connected to P- side and (–ve) terminal is connected the n side, then diode is said to be forward biased condition. In this condition the height of the potential barrier at the junction is lowered by an amount equal to given forward biasing voltage. Both the holes from p-side and electrons from n-side cross the junction simultaneously thereby decreasing the depleted region. This constitutes a forward current (majority carrier movement – diffusion current). Assuming current flowing through the diode to be very large, the diode can be approximated as short- circuited switch. Diode offers a very small resistance called **forward resistance (few ohms)**

Reverse bias operation

If negative terminal of the input supply is connected to p-side and (–ve) terminal is connected to n-side then the diode is said to be reverse biased. In this condition an amount equal to reverse biasing voltage increases the height of the potential barrier at the junction. Both the holes on P-side and electrons on N-side tend to move away from the junction there by increasing the depleted region. However the process cannot continue indefinitely, thus a small current called reverse saturation current continues to flow in the diode. This current is negligible; the diode can be approximated as an open circuited switch it offers a very high resistance called **reverse resistance(few Kilo Ohms)**.

Static Resistance: The opposition offered by a diode to the direct current flowing forward bias condition is known as its **DC forward resistance** or Static Resistance. It is measured by taking the ratio of DC voltage across the diode to the DC current flowing through it at an operating point.

Dynamic Resistance: The opposition offered by a diode to the changing current flow I forward bias condition is known as its **AC Forward Resistance**. It is measured by a ratio of change in voltage across the diode to the resulting change in current through it for an operating point P.

(b) Reverse Bias Condition:

1. Connect the circuit as shown in Fig.2 (Point contact diode in series with micro ammeter).
2. Vary V_s in the Regulated Power Supply (RPS) gradually in steps of 1V from 0V to 12V and note down the corresponding readings V_r and I_r .
3. Tabulate different reverse currents obtained for different reverse voltages.
4. Plot the V-I characteristics and calculate the resistance levels
5. Compare the theoretical and practical values.

Calculations from Graph:

(a) Forward Bias of PN Junction Diode:

- | | |
|------------------------------|--------------------------------|
| 1. Cut-in Voltage | $V_\gamma =$ |
| 2. Static forward Resistance | $R_{dc} = V_f / I_f$ |
| 3. Dynamic Forward Average | $r_{ac} = \Delta V / \Delta I$ |

(b) Reverse Bias of Point contact diode:

Similarly find static and dynamic resistance

Experiment No: 2

Zener Diode Characteristics

Object:

To study and measure the effects of forward and reverse bias on the zener diode current. To construct a zener voltage regulator and experimentally determine the range over which the zener maintains a constant output voltage.

Theory: However, the Zener Diode or “Breakdown Diode”, as they are sometimes referred to, are basically the same as the standard PN junction diode but they are specially designed to have a low and specified Reverse Breakdown Voltage which takes advantage of any reverse voltage applied to it. The Zener diode behaves just like a normal general-purpose diode consisting of a silicon PN junction and when biased in the forward direction, that is Anode positive with respect to its Cathode, it behaves just like a normal signal diode passing the rated current. However, unlike a conventional diode that blocks any flow of current through itself when reverse biased, that is the Cathode becomes more positive than the Anode, as soon as the reverse voltage reaches a pre-determined value, the zener diode begins to conduct in the reverse direction. This is because when the reverse voltage applied across the zener diode exceeds the rated voltage of the device a process called Avalanche Breakdown occurs in the semiconductor depletion layer and a current start to flow through the diode to limit this increase in voltage. The current now flowing through the zener diode increases dramatically to the maximum circuit value (which is usually limited by a series resistor) and once achieved, this reverse saturation current remains fairly constant over a wide range of reverse voltages. The voltage point at which the voltage across the zener diode becomes stable is called the “zener voltage”, (V_z) and for zener diodes this voltage can range from less than one volt to a few hundred volts.

Zener Diode I-V Characteristics

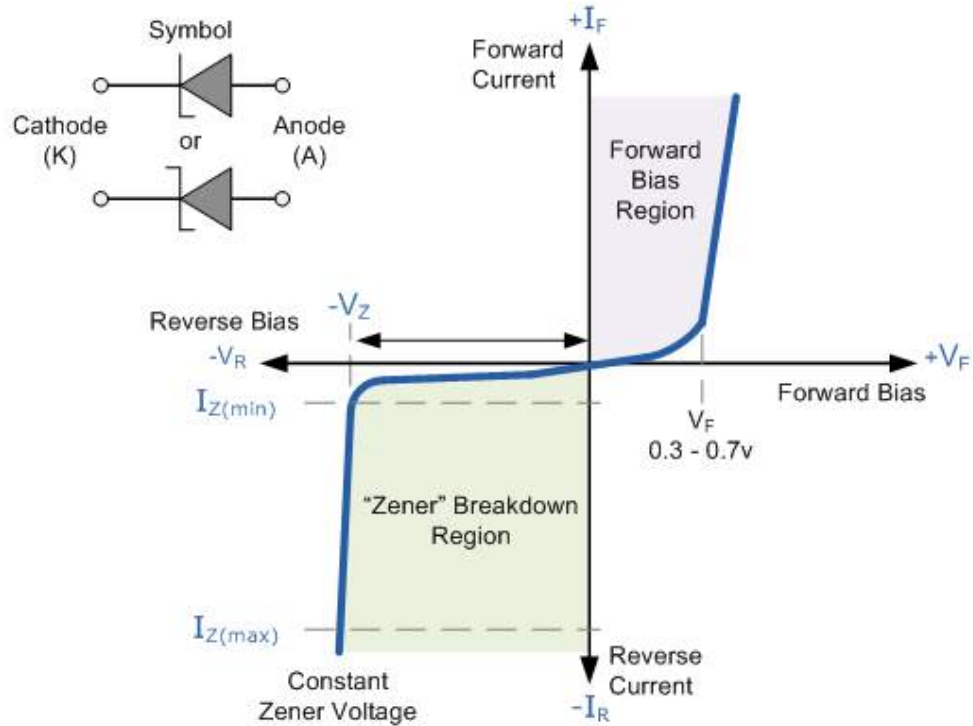

The Zener Diode is used in its “reverse bias” or reverse breakdown mode, i.e. the diodes anode connects to the negative supply. From the I-V characteristics curve above, we can see that the zener diode has a region in its reverse bias characteristics of almost a constant negative voltage regardless of the value of the current flowing through the diode. The Zener Diode Regulator Zener Diodes can be used to produce a stabilized voltage output with low ripple under varying load current conditions. By passing a small current through the diode from a voltage source, via a suitable current limiting resistor (R_S), the zener diode will conduct sufficient current to maintain a voltage drop of V_{out} . We remember from the previous tutorials that the DC output voltage from the half or full-wave rectifiers contains ripple superimposed onto the DC voltage and that as the load value changes so too does the average output voltage. By connecting a simple zener stabilizer circuit as shown below across the output of the rectifier, a more stable output voltage can be produced.

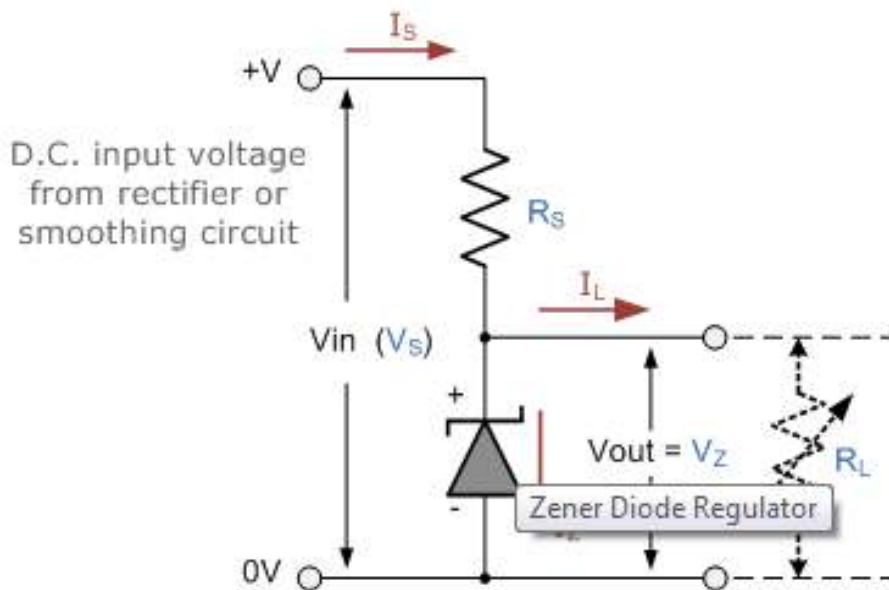

Procedure A:

1. Connect the circuit shown in Figure (1), the power supply is set to zero volts.
2. Measure and record in table (1), the forward current in the diode at each level of Voltage (V_f)
3. Determine the forward resistance $R_f = \frac{V_f}{I_f}$

Procedure B:

1. Reverse the diode in the circuit of Figure (1).
2. Measure and record in the table (2), the reverse current in the diode at each level of voltage.
3. Calculate $R_z = \frac{V_z}{I_z}$ and record the result in table (2)

Discussion

1. What are the differences between a normal diode and a zener diode?
2. Explain how the regulator circuit in Figure (2), works?
3. If you are going to design a regulator circuit, what are the important parameters that should know about the zener ?

Experiment No. 3

Half –Wave Rectifier

The unidirectional conducting property of diode finds great application in rectifiers. These are circuits which convert an ac voltage into dc voltage with respect to its cathode. In half wave rectifier circuit, during positive half cycle of the input, the diode gets forward biased and it conducts current flows through the load resistance R_L and voltage is developed across it. During the negative half cycle of the input, the diode gets reverse biased, now no current flows (except the leakage current which is very small). The voltage across the load resistance during the period of input cycle is zero. Thus a pure ac signal is converted into a unidirectional signal. The output signal contains ac and dc components.

METHOD:

Connected AC source of amplitude $V_m = 6\text{v}$ and frequency about 100Hz or more to input terminal AB. Connected output at CD to CRO and draw the output signal across R_L . See or draw V_{dc} by putting CRO on V_{dc} position. For V_{ac} put CRO on V_{ac} position. Now connect the capacitor C parallel to R_L and see the output signal for both component V_{dc} and V_{ac} . Now take the measurement and discuss your result.

$R = 1\text{K}\Omega$ $C = 0.1, 0.5 \text{ and } 1\mu\text{F}$

Repeat the same with $R = 10\text{K}\Omega$ and $R = 100\text{K}\Omega$

Applications of Half wave rectifier

Any rectifier is used to construct DC power supplies. The practical application of any rectifier (be it half wave or full wave) is to be used as a component in building DC power supplies. A half wave rectifier is not special than a full wave rectifier in any terms. In order to build an efficient & smooth DC power supply, a full wave rectifier is always preferred. However, for applications in which a constant DC voltage is not very essential, you can use power supplies with half wave rectifier.

Half Wave Rectification

A rectifier is a circuit which converts the Alternating Current (AC) input power into a Direct Current (DC) output power. The input power supply may be either a

single-phase or a multi-phase supply with the simplest of all the rectifier circuits being that of the Half Wave Rectifier. The power diode in a half wave rectifier circuit passes just one half of each complete sine wave of the AC supply in order to convert it into a DC supply. Then this type of circuit is called a “half-wave” rectifier because it passes only half of the incoming AC power supply as shown below.

part A

Half Wave Rectifier Circuit

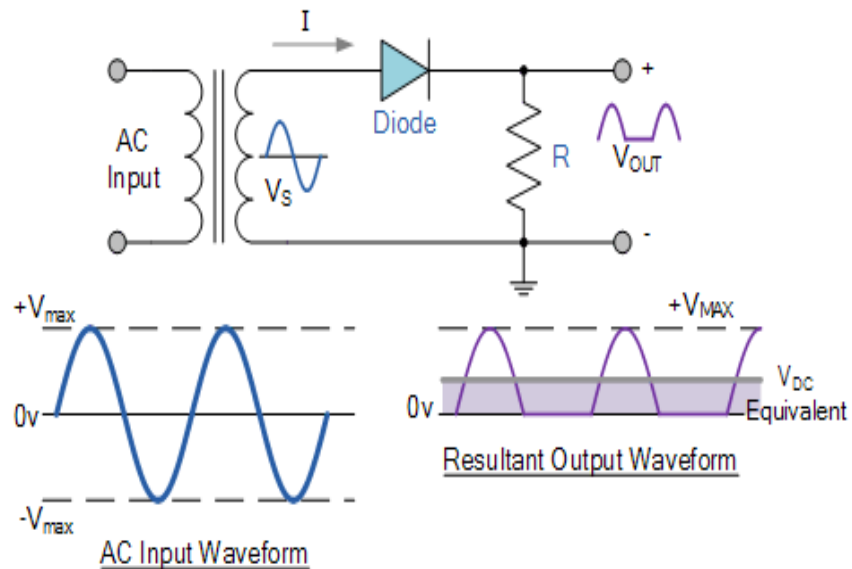

During each “positive” half cycle of the AC sine wave, the diode is forward biased as the anode is positive with respect to the cathode resulting in current flowing through the diode. Since the DC load is resistive (resistor, R), the current flowing in the load resistor is therefore proportional to the voltage (Ohm’s Law), and the voltage across the load resistor will therefore be the same as the supply voltage, that is the “DC” voltage across the load is sinusoidal for the first half cycle only so $V_{out} = V_s$.

During each “negative” half cycle of the AC sinusoidal input waveform, the diode is reverse biased as the anode is negative with respect to the cathode. Therefore, NO current flows through the diode or circuit. Then in the negative half cycle of the supply, no current flows in the load resistor as no voltage appears across it so therefore, $V_{out} = 0$

part B

Half-wave Rectifier with Smoothing Capacitor

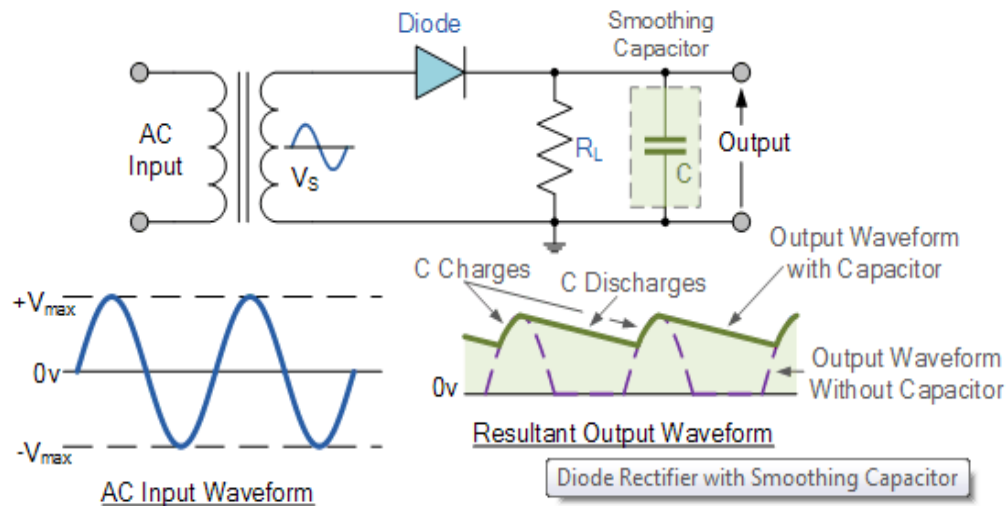

Ripple factor

$$r = \frac{1}{2\sqrt{3} f R_L C}$$

When rectification is used to provide a direct voltage (DC) power supply from an alternating (AC) source, the amount of ripple voltage can be further reduced by using larger value capacitors but there are limits both on cost and size to the types of smoothing capacitors used.

For a given capacitor value, a greater load current (smaller load resistance) will discharge the capacitor more quickly (RC Time Constant) and so increases the ripple obtained. Then for single phase, half-wave rectifier circuit using a power diode it is not very practical to try and reduce the ripple voltage by capacitor smoothing alone. In this instance it would be more practical to use “Full-wave Rectification” instead.

In practice, the half-wave rectifier is used most often in low-power applications because of their major disadvantages being. The output amplitude is less than the input amplitude, there is no output during the negative half cycle so half the power is wasted and the output is pulsed DC resulting in excessive ripple.

To overcome these disadvantages a number of Power Diode are connected together to produce a Full Wave Rectifier as discussed in next experiment

Experiment No. 4 Full – Wave Rectifier

P-N' junction diode can be used as a full wave rectifier fig.(1) shows a bridge circuit for full wave rectification . Such a circuit is capable of producing a positive output voltage.

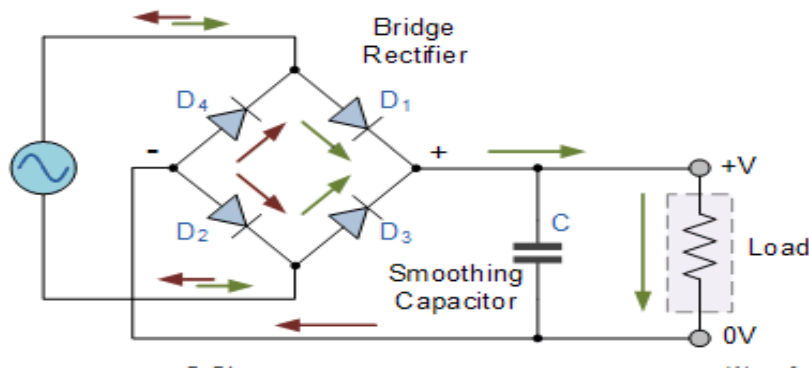

The diodes in the bridge circuit operate in pairs, for the first half cycle, first pair (D1 & D2) conducts heavily and for the next half cycle the other pair (D3 & D4) conducts heavily. One pulse is obtained for such half cycle of input, or two pulses for every cycle -input. During the first half cycle of the input, it is found that D1 and D2 are forward biased and conducts heavily from time t_1 and t_2 charging the capacitor C to the peak value of the input voltage. At t_1 the voltage at point A of the circuit has dropped below V_L and these diodes turn off, from t_2 to t_3 all diodes are off, because of reverse biasing. The circuit in the load is supplied by the energy stored in C, with slowly discharge. At t_3 the voltage at B has risen to sufficiently high value to turn on diodes D3 and D4. A current pulse charges to the peak value from t_4 to t_5 , the diodes are again off and cycle starts again at t_5 .

The Diode Bridge Rectifier

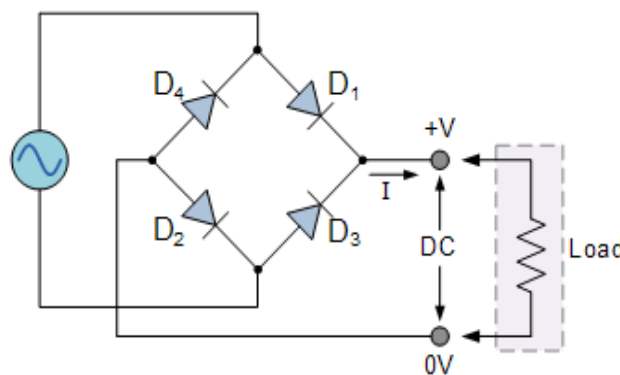

The four diodes

labelled D1 to D4 are arranged in “series pairs” with only two diodes conducting current during each half cycle. During the positive half cycle of the supply, diodes D1 and D2 conduct in series while diodes D3 and D4 are reverse biased and the current flows through the load as shown below.

The Positive Half-cycle

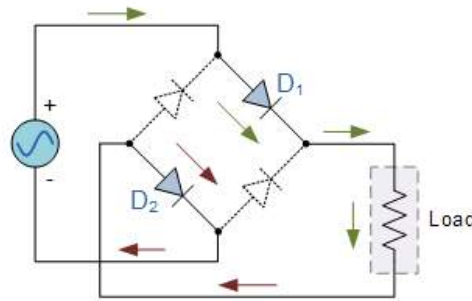

During the negative half cycle of the supply, diodes D3 and D4 conduct in series, but diodes D1 and D2 switch “OFF” as they are now reverse biased. The current flowing through the load is the same direction as before.

The Negative Half-cycle

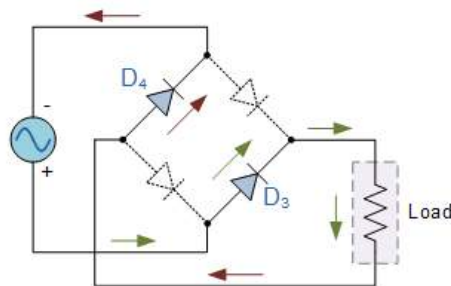

As the current flowing through the load is unidirectional, so the voltage developed across the load is also unidirectional the same as for the previous two diode full-wave rectifier, therefore the average DC voltage across the load is $0.637V_{max}$

The Smoothing Capacitor

We saw in the previous section that the single phase half-wave rectifier produces an output wave every half cycle and that it was not practical to use this type of circuit to produce a steady DC supply. The full-wave bridge rectifier however, gives us a greater mean DC value ($0.637 V_{max}$) with less superimposed ripple while the output waveform is twice that of the frequency of the input supply frequency.

We can improve the average DC output of the rectifier while at the same time reducing the AC variation of the rectified output by using smoothing capacitors to filter the output waveform. Smoothing or reservoir capacitors connected in parallel with the load across the output of the full wave bridge rectifier circuit increases the average DC output level even higher as the capacitor acts like a storage device as shown below.

METHOD:

Measure V_{ac} and V_{dc} with the different combination of R and C and calculate the ripple factor with these values; $R=1.0K\Omega$, $C=0.1, 0.5, 1.5$).tf Repeat the same with $R=10K\Omega$ and $100K\Omega$ with the same value of C and discuss your result.

Full-wave Rectifier with Smoothing Capacitor

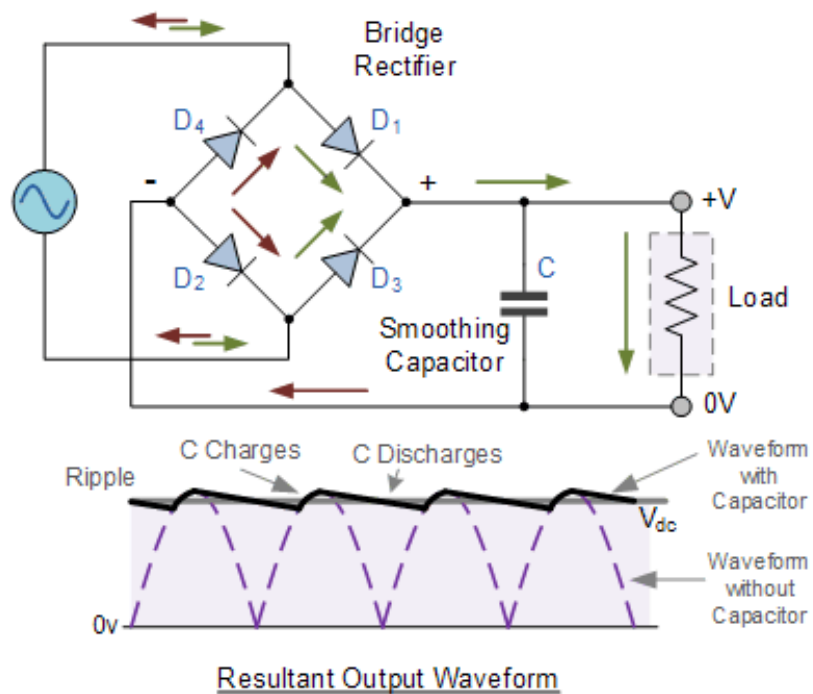

$$\text{Ripple factor } r = \frac{1}{4\sqrt{3} f R_L C} = \frac{V_{ac}}{V_{dc}} \times 2$$

Experiment No: 5

Clipping Circuits

Objective:

- To understand the theory of operation of the clipping diode circuits.
- To design wave shapes that meet different circuits needs.

Introduction

By definition, clipping circuits clip signals above a selected voltage level, whereas clamping circuits shift the DC voltage of a waveform. Many wave shapes can be produced with the proper application of these two important diode functions.

Theory: The diode has many applications. In this lab, a few of them will be investigated. The first is the clipper circuit. This circuit limits an input voltage to certain minimum and maximum values. In the circuit in Figure 2-1, one can see that as long as V_{in} is less than V_{B1} , then the diode will be reverse biased (an open circuit). In this case, the output voltage will track the input voltage. If V_i exceeds V_{B1} then the diode turns on and then V_o will be V_{B1} thus this circuit limits the output voltage to less than V_{B1} . By rearranging the components, variations on this circuit can be achieved.

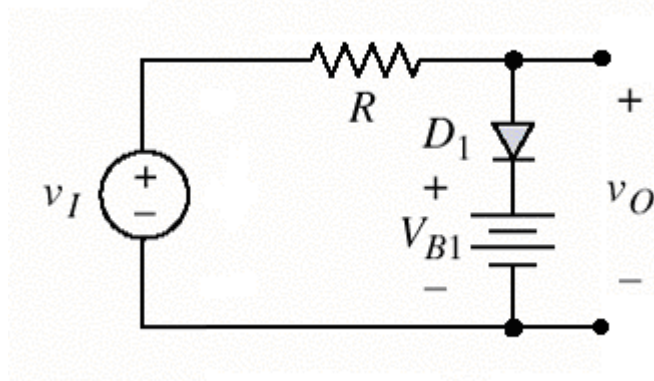

Figure 2-1: Schematic of a clipper circuit.

Procedure:

Diode clipper circuits can be used to limit a voltage to some maximum or minimum value. This is useful for designing protection circuits.

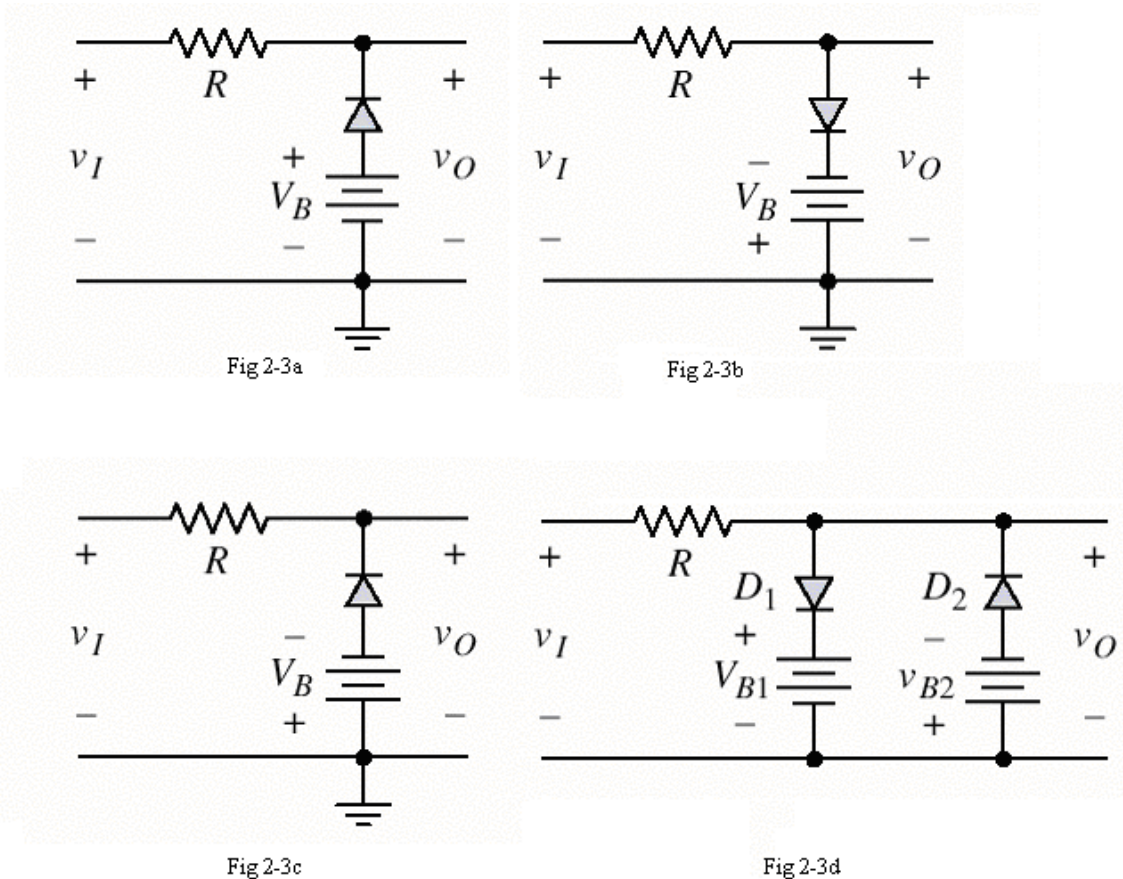

Figure 2-3: Clipper Circuits

- Connect the circuit in Figure 2-3a. Use $R = 100 \text{ k}\Omega$ and a diode. For the input signal, use 5Vp-p, 1kHz sine wave and use power supply to provide the battery voltage. Measure and sketch the input and output waveforms.
- Repeat the procedure for the remaining circuits.

Questions for the Lab Report: Discuss the output waveforms from the clipper circuits. How do these waveforms differ from those expected if ideal diodes were used? Why?

Simple Series Clippers (Ideal Diodes)

POSITIVE

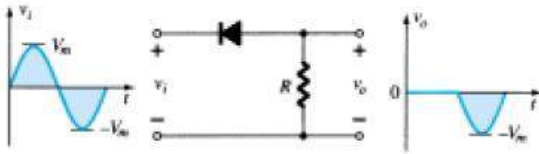

NEGATIVE

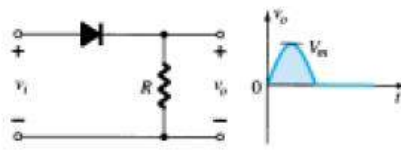

Biased Series Clippers (Ideal Diodes)

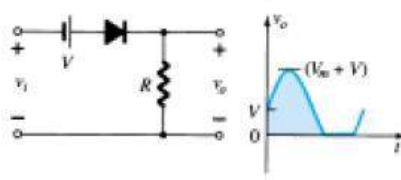
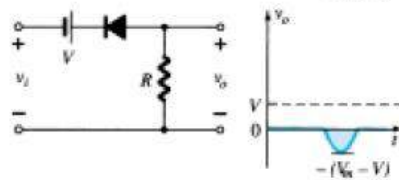
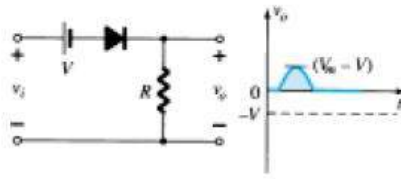
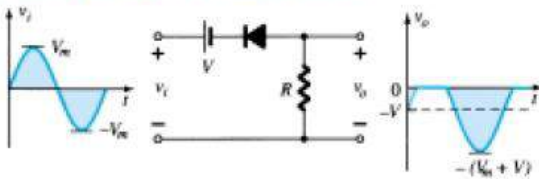

Simple Parallel Clippers (Ideal Diodes)

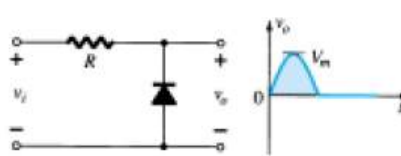
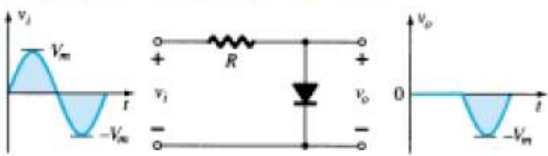

Biased Parallel Clippers (Ideal Diodes)

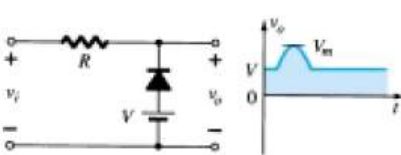
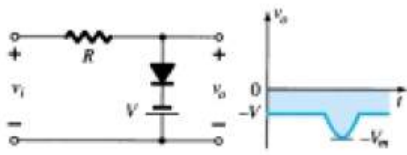
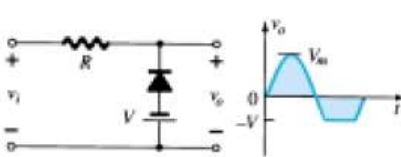
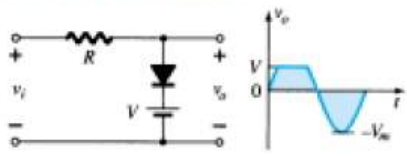

Experiment No:(6) Clamping Circuits

Objective:

- To understand the theory of operation of the clamping diode circuits.
- To design wave shapes that meet different circuits needs.

Theory: Consider a negative clamping circuit, a circuit that shifts the original signal in a vertically downward direction, as shown in the figure below. The diode D will be forward biased and the capacitor C is charged with the polarity shown, when an input signal is applied. During the positive half cycle of input, the output voltage will be equal to the barrier potential of the diode, V_0 and the capacitor is charged to $(V - V_0)$. During the negative half cycle, the diode becomes reverse-biased and acts as an open-circuit. Thus, there will be no effect on the capacitor voltage. The resistance R, being of very high value, cannot discharge C a lot during the negative portion of the input waveform. Thus during negative input, the output voltage will be the sum of the input voltage and the capacitor voltage and is equal to $-V - (V - V_0)$ or $-(2V - V_0)$. The value of the peak-to-peak output will be the difference of the negative and positive peak voltage levels is equal to $V_0 - [-(2V - V_0)]$ or $2V$.

The figure shown below can be modified into a positive clamping circuit by reconnecting the diode with reversed polarity. The positive clamping circuit moves the original signal in a vertically upward direction. A positive clamping circuit is shown in the figure below. It contains a diode D and a capacitor C as are contained in a negative clamper. The only difference in the circuit is that the polarity of the diode is reversed. The remaining explanation regarding the working of the circuit is the same as it is explained for the negative clamper.

Negative Clamper

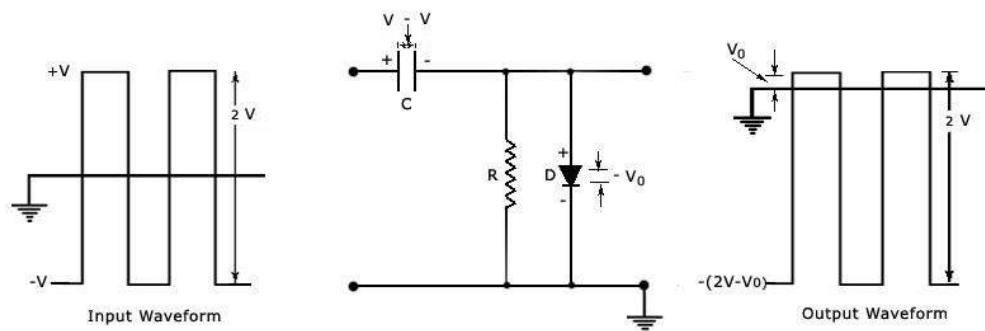

Similarly, in the figure shown below, the diode arrow points upward, again the same direction as the dc shifts. It means that when the diode points upward. We have a positive dc clamper and when the diode points downward, the circuit is a negative dc clamper.

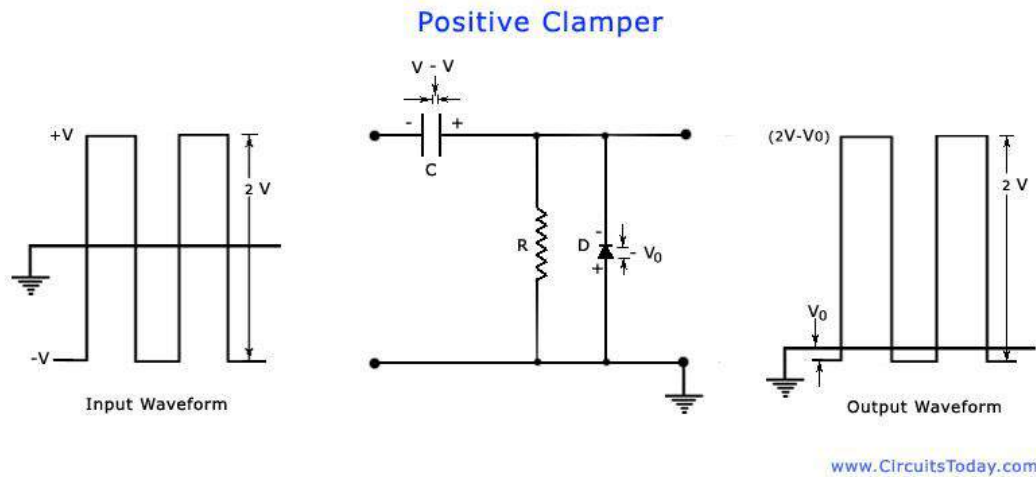

Procedure:

1. Connected the circuit as shown in figure (1) where $C = 0.01\mu\text{f}$.
2. Take from signal generator square wave as an input voltage (V_i) with amplitude 4V and frequency 10KHz.
3. Draw the output voltage (V_o) and input voltage (V_i) for the different cases; $V_1 = 0, +1.5$ and -1.5 V.
4. Draw the output voltage for the cases; $F = 100\text{KHz}$ and $V_1 = +1.5$.
5. Draw the output voltage for the cases; $C = 0.0001\mu\text{f}, 32\mu\text{f}$.
6. Repeat steps (2), (3) and (4) for the circuit an in figure (2).
7. Discuss the result in detail.

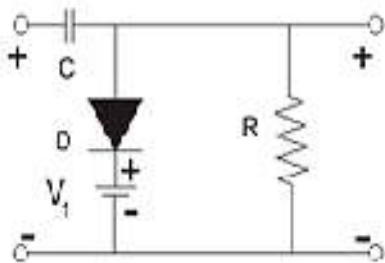

Figure (1): Negative clamper circuit

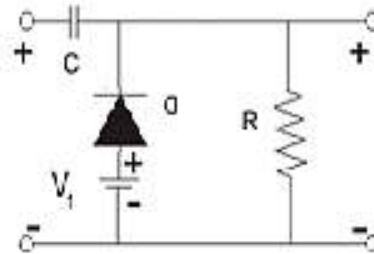

Figure (2): Positive clamper circuit

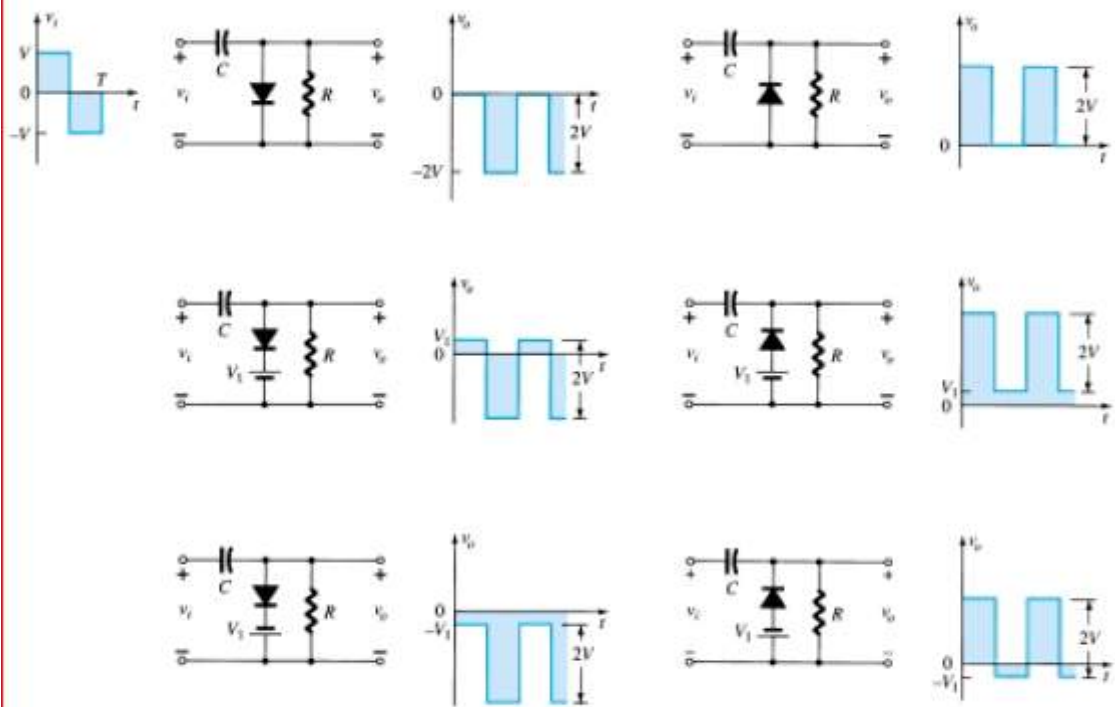

Figure 2.103 Clamping circuits with ideal diodes ($5\tau = 5RC \gg T/2$).

Experiment No: 7

Doubling Voltage

Objective:

- To observe the function of voltage multiplier

Theory:

The Voltage Doubler, as its name suggests, a **Voltage Doubler** is a voltage multiplier circuit which has a voltage multiplication factor of two. The circuit consists of only two diodes, two capacitors and an oscillating AC input voltage (a PWM waveform could also be used). This simple diode-capacitor pump circuit gives a DC output voltage equal to the peak-to-peak value of the sinusoidal input. In other words, double the peak voltage value because the diodes and the capacitors work together to effectively double the voltage.

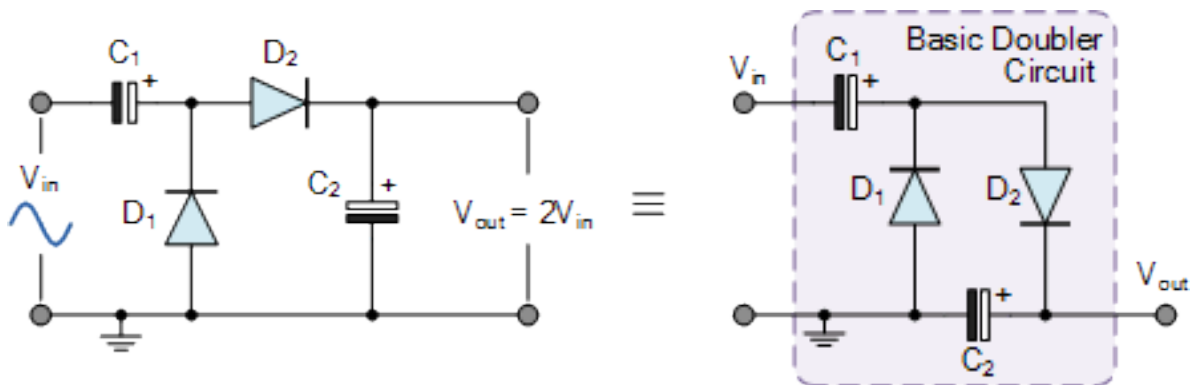

So how does it work? The circuit shows a half wave voltage doubler. During the negative half cycle of the sinusoidal input waveform, diode D_1 is forward biased and conducts charging up the pump capacitor, C_1 to the peak value of the input voltage, (V_p). Because there is no return path for capacitor C_1 to discharge into, it remains fully charged acting as a storage device in series with the voltage supply. At the same time, diode D_2 conducts via D_1 charging up capacitor, C_2 . During the positive half cycle, diode D_1 is reverse biased blocking the discharging of C_1 while diode D_2 is forward biased charging up capacitor C_2 . But because there is a voltage across capacitor C_1 already equal to the peak input voltage, capacitor C_2 charges to twice the peak voltage value of the input signal. In other words, $V(\text{positive peak}) + V(\text{negative peak})$, so on the negative half-cycle, D_1 charges C_1 to V_p and on the positive half-cycle D_2 adds the AC peak voltage to V_p on C_1 and transfers it all to C_2 . The voltage across capacitor, C_2 discharges through the load ready for the next half cycle. Then the

voltage across capacitor, C_2 can be calculated as: $V_{out} = 2V_p$, (minus of course the voltage drops across the diodes used) where V_p is the peak value of the input voltage. Note that this double output voltage is not instantaneous but increases slowly on each input cycle, eventually settling to $2V_p$. As capacitor C_2 only charges up during one half cycle of the input waveform, the resulting output voltage discharged into the load has a ripple frequency equal to the supply frequency, hence the name half wave voltage doubler.

Procedure:

1. Connected the circuit as shown.
2. Take the input voltage from the signal generator equal to 3V in amplitude and frequency 1KHz.
3. Draw the input and the output Voltage waveform for the following cases: $R_L = 1M\Omega, 470 K\Omega, 100K\Omega, 47K\Omega, 10K\Omega, 1K\Omega$.
4. Draw the graph between V_o and $f(R_L)$.
5. Draw the output voltage waveform for the following cases: $R_L = 100K\Omega, C_1 = 0.01\mu f$.
6. Repeat the step (5) for the following cases: $C = 0.001\mu f, 0.01\mu f$ and $f = 10KHz$.
7. Discuss the result in detail.

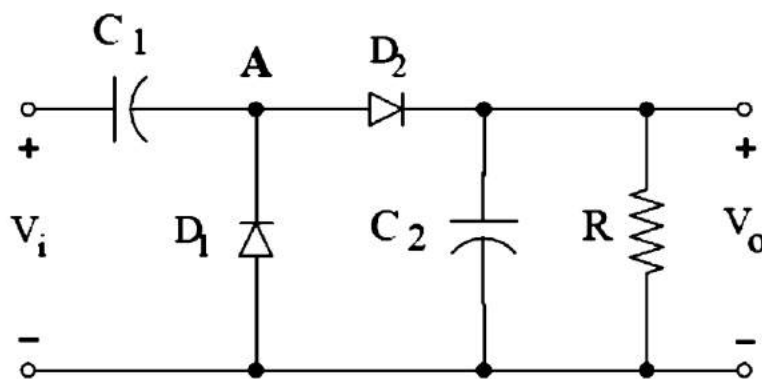

Figure: Voltage Doubler Circuits