



Experimental and Numerical Analysis of Brake Disc Modal Behaviour

Dr. Kareem Abdulghafour Abdulla

Mechanical and Mechatronics department, Engineering College, Salahaddin University, Erbil, Iraq
Kareem.abdulla@su.edu.krd

Dr. Chalang Hamarasheed Mohammed

Mechanical and Mechatronics department, Engineering College, Salahaddin University, Erbil, Iraq
chalang.mohammed@su.edu.krd

ARTICLE INFO

Article History:

Received:

Accepted:

Published:

Keywords:

Experimental Modal Analysis, Disc Brake, Disc Thickness Variation, MATLAB Simulink

ABSTRACT

The aim of this study is to use numerical approaches, specifically FEA and MATLAB Simulink, and experimental modal analysis to investigate the structural dynamic behaviour of disc brakes; based on different wear thickness. The impact hammer test (a modal analysis excitation technique) has been performed to find out the brake disc structure modal parameters; particularly the brake disc's natural frequencies. Due to the fact that the measurements were made using the actual disc brake structure can be utilized to justify the natural frequency derived from finite element modelling. The disc brake rotors in this work has wear thicknesses of 0.5 mm, 1.0 mm, and 1.5 mm compared to their original thickness of 20 mm with weight of 4.20 kg. An impact hammer experiment is employed to obtain the modal parameters, such as natural frequency, damping ratio, and mode shape, under a free-free state. The first four natural frequencies for a disc brake rotor with its original thickness are 532 Hz, 525 Hz, and 521 Hz, and 538 Hz respectively. The results show that the natural frequency drops as the thickness reduction increases at the same mode. Since wear reduces the disc brake rotor's natural frequency, it can be inferred that this is one of the factors that might be causing the brake squeal issue. In addition, models examined by the MATLAB Simulink to find theoretically the



natural frequency (or the resonant frequency; since the value of damping ratio is too small) of the process via bode plot criterion of stability. The results were near to those obtained practically.

Introduction

The disc is the most crucial component of the braking system. The safety of driving the vehicle is affected by its operation. When the car squeals, the excitation frequency of the brake disc is almost at its natural frequency. This causes resonance, produces a lot of vibration and noise, and reduces ride comfort.

In reality, uncertainties regarding the true geometry and material properties frequently place a limit on the accuracy of the disc brake rotor in FEM models. Therefore, in order to compare the observed vibration behaviour of disc brake components with that anticipated by FEA from the earlier research, experimental modal analysis is used from the previous studied by Daut [1]. The disc brake's thickness variation demonstrated how the rotor-pad coupling mechanism wears. Since the coupling mechanisms are altered, this wear has a significant impact on process instability and noise production. Brake squealing may arise when the system reaches the end of its useful life due to change in the geometry and stiffness properties of the rotor and brake pads caused by wear [2]. Since the air gap creates between the pad shoes and wheel reduces the magnitude of process stiffness, hence resonant frequency will reduce [3].

Furthermore, a hammer excitation measuring technique was employed by (NK Kharate, SS Chaudhari) to confirm the physical vibration properties of a brake disc through modal analysis. The brake disc was examined under free-free boundary conditions, and a laboratory experiment was used to confirm the findings. These analyses indicate that the first mode was detected in the experimental analysis at

1526 Hz and in the finite element analysis at 1557.6 Hz [4]. Kung S. deployed a structural dynamic measurement on a dynamometer panel for verifying the brake components' modal analysis outcomes. For disc, he found a 7% discrepancy between numerical and experimental analyses [5]. A theoretical and experimental analysis of the braking system components was conducted by Papinniemi A. et al. The impact hammer method was employed in the experimental analysis to determine the rotor's circumferential in-plane modes. The first and second circumferential in-plane modes were therefore determinate [6]. Nouby used experimental testing in 2012 to prove a numerical analysis of the braking process. At this point the first three modal eigenvalues for the disc were found, and this time, the first mode had 0% error, the second had 1.2%, and the third had 3% error [7]. Holger Marschner et al. compared the outcomes of 3-D laser vibrometer measurement procedures with those of finite element methods in their paper [8]. A lordache conducted a finite elements analysis of the modal behaviour of a brake disc. An experimental study confirmed the modal analysis. Based on the achieved frequency similarity, the model was partially approved through an experimental approach [9].

This study suggests that thinned out the disc brake rotor at the point of frictional engagement with the brake pad could alleviate the disc brake squeal problem. Next, the effect of wear on the disc rotor was investigated using experimental modal analysis. The experiment yields data on the mode shapes, damping ratio, and natural frequency of the disc rotor—all of which can contribute to brake squeal and be helpful in predicting and preventing it. A MATLAB software (Simulink Model) is used to determine the stiffness and natural frequency for this part (process) and compare with the experimental data.

1. Modal Analysis Theory

Components with dissipative energy aspects and distributed energy storage typically make up complex vibration systems. Within these systems, the space location continuously modifies the inertial, stiffness, and damping characteristics. To show

their response over vibrations, partial differential equations involving space coordinates and time t as independent variables are always required [10].

The following variables are used to define the second order equation of motion for a brake process that is defined by the ordinary differential equation with a single degree of freedom and consists of the brake disc:

Where; m is mass, k is the spring stiffness, c is the damping coefficient, F is the friction force and x is the distance and both are the functions of the t (time) [10].

$$m\ddot{x}(t) + c\dot{x}(t) + kx(t) = F(t) \quad (1)$$

The optimum method to find natural frequency is to consider the system as free vibration, when $F = 0$ and $c = 0$, then the results are as follows:

$$m\ddot{x}(t) + kx(t) = 0 \quad (2)$$

The general form of solving equation (2) is:

$$x = X e^{j\omega t} \quad (3)$$

The necessary and sufficient condition for a non-zero solution of equation (1) is that the determinant of coefficient matrix is zero, and the characteristic equation (1) can be obtained by solving:

$$|K - \omega^2 M| x = 0 \quad (4)$$

For an n -degree-of-freedom system, the system displacement x cannot be zero at same time. The above formula has a solution, so the equation (4) is valid only when the coefficient matrix is 0, namely:

$$|K - \omega^2 M| = 0 \quad (5)$$

The natural frequency of the system can be obtained by using equation (3) [10]:

$$f_n = \frac{\omega_n}{2\pi} \quad (6)$$

2. Experimental Modal Analysis (EMA)

2.1 Materials & Instrumentation and measuring equipment:

For this analysis, one new commercial brake disc was used and the material, Grey cast iron, which the detailed properties shown in Table1.

Table (1): Material properties of Gray cast iron

Material Properties	
Young's modulus E	$1 * 10^5$ MPa
Poisson's ratio ν	0.27
Bulk Modulus	72464 MPa
Compressive U. Strength	820 MPa
Tensile Ultimate Strength	240 MPa
Shear Modulus	39370 MPa
Density ρ	6060 Kg/m ³

As part of the modal test procedure, a structure's FRFs, or impact responses, are calculated. To find the vibration responses in one or more locations and verifying that the structure is excited in the absence of any other stimulating is all that is needed to determine the FRF. Modern excitation techniques combined with advances in modal analysis theory allow for more complex excitation mechanisms. The sources of excitation can be white noise, random, transient, or specific band frequencies. The response point is usually measured at the driver by a force transducer, although accelerometers or other sensors can also be used. Both the excitation and response signals are sent to an analyser, whose job it is to compute the instrument data for the FRF [11].

The number of tests modal FRF data required to accurately derive the modal model of the item being measured is a practical requirement. Then, is left fixed to the response observation when an impact hammer test is conducted, and the excitation location is moved by force point variously. The measured data consist of a FRF matrix with one row. Theoretically, this data would be enough to construct the modal model.

The following stages comprise the experimental method for simulating the dynamic behaviours of structures using impact hammer test modal testing (Fig.(1):

- Configuring the modality test
- Obtaining the measurements
- Analysing the measured test data
- Monitored outcomes and comparisons with modelled data
- Using an impact hammer (Dytran Make 5800B3), the structure was excited at all predetermined locations, as shown in Fig. (2)
- Piezoelectric accelerometer, model (PCB T30356B1 & 30356B1 G), with 100 mV/g sensitivity, at an identified driving point transfer function (DPTF) location. The type of experimental modal analysis is known as the Frequency Response Function (FRF).
- Joining the accelerometer and impact hammer connections,
- The impact hammer and accelerometer signals are received, and they are analysed, using a sound and vibration data acquisition system.
- Personal Computer, in order to extract natural frequencies and mode shapes, the essence of all frequency response functions (FRFs) was figured out. The experimental modal analysis setup for the brake disc is shown in Fig. 3.

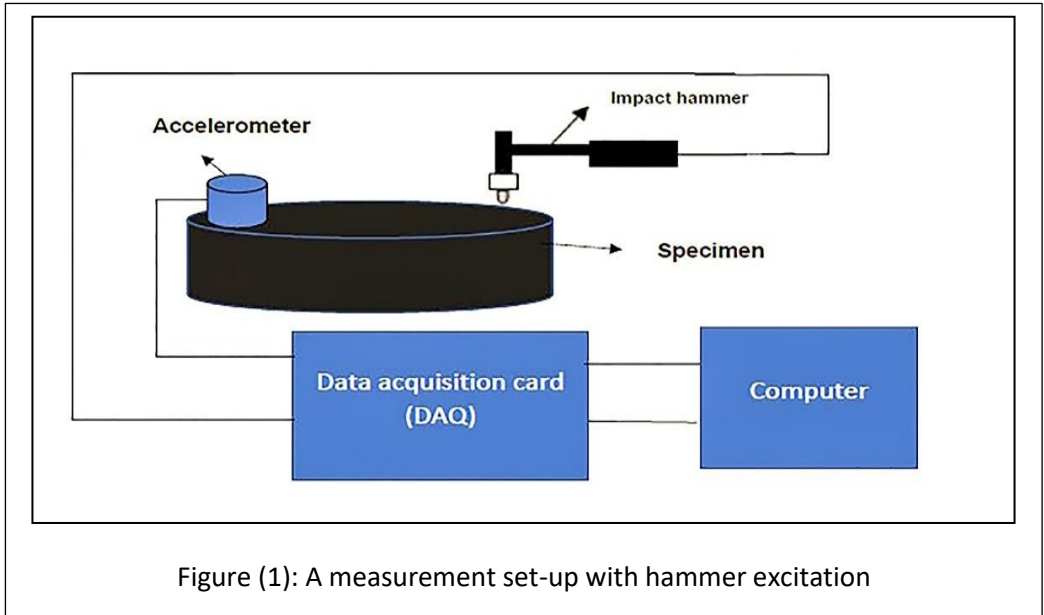

2.2 Experimental Modal Analysis (EMA) Procedure

The specimen was positioned on the 39,64 kg/m³ density with 370 x 300 x 15 mm dimensions in order to allow free vibration (see Fig.(3)). The brake disc was tested through the experimental modal analysis with free – free boundary conditions (see Fig.2&Fig.3).

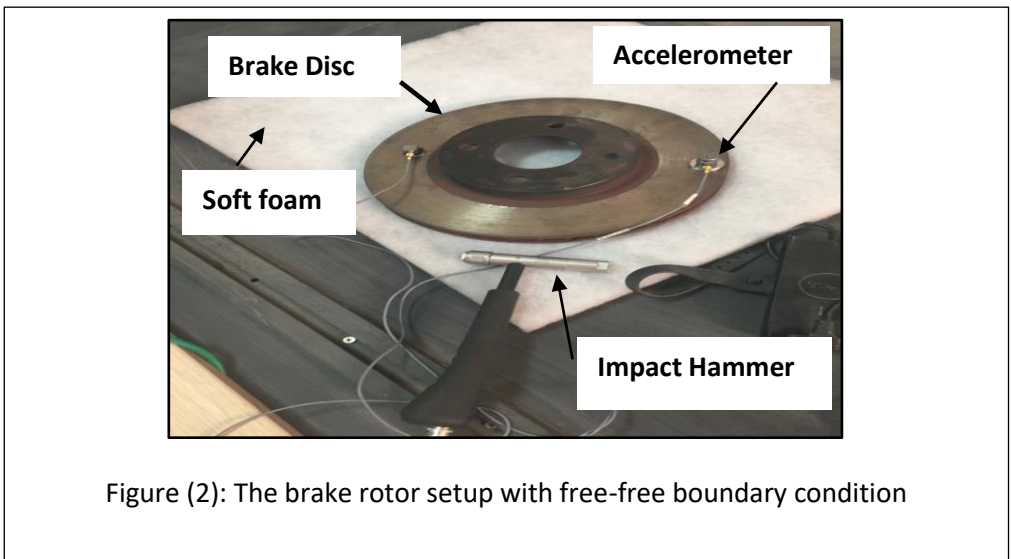

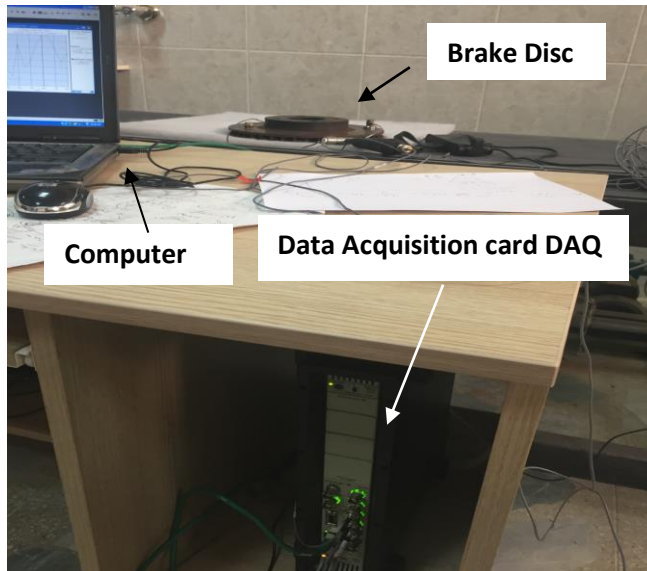

Figure (3): The experimental setup for impact hammer test

Measurement of Damping

For first natural frequency of the experiment, half-power band-width procedure was used to calculate damping responses. Damping is expressed in various ways in mechanical systems and the most common types are Q and ζ ; here Q is amplification factor (magnitude), and ζ the viscous damping ratio. The damping ratio from the frequency domain is also estimated using the half power bandwidth method; on a decibel scale, this correlates to a 3db drop from the peak. This is why the damping measurement method is also known as the 3db method. When the 3db point appears on the transfer magnitude curve, it is also referred to as a "half power point". The corresponding damping can be found by observing 3 dB below the peak level, as seen in Fig. 4 and according to Equation (7) (SiemensAktiengesellschaft) [10] [12].

As explained in the text the sound of noise is not treated as an external force, but it is an indicator of the external frequency reaching to near the brake natural frequency. Figure (4) shows the limit that the sound created was in the rang $[f_1, f_2]$. Typically, a

Bode plot is used to display the FRF. In the Bode magnitude plot, natural frequencies will be easily seen as a peak (Aarønes 2015, Saini 2021)[14, 16].

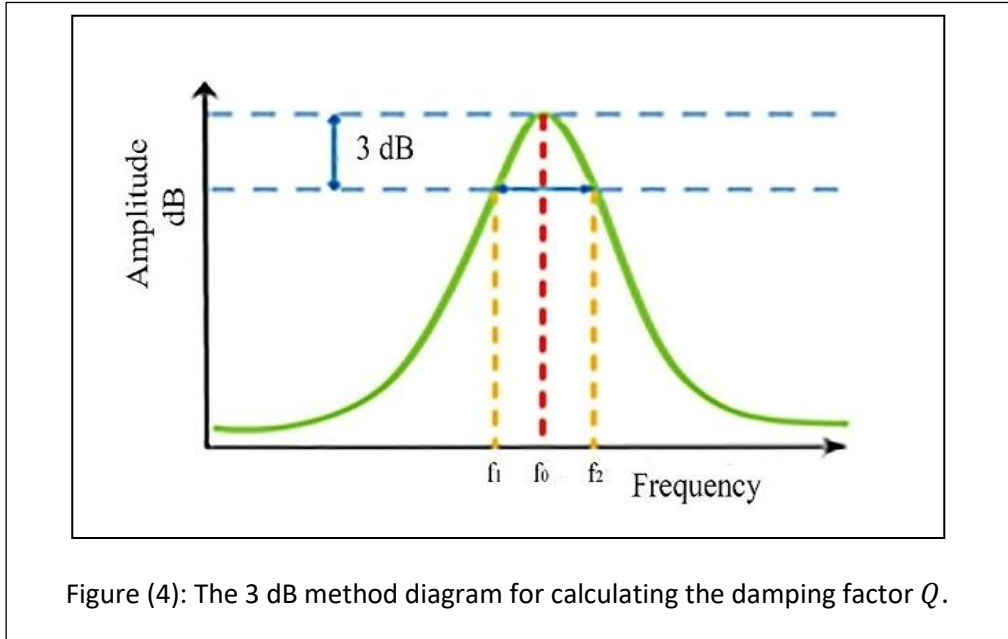

$$\zeta = \frac{1}{2Q} = \frac{f_2 - f_1}{2f_0} \quad \dots (7)$$

3. Numerical Solution

3.1 Finite Element Analysis(FEA)

The ANSYS Workbench software's modal analysis module is used to carry out the modal analysis. After that, the geometric model of the brake disc is imported, the material properties are adjusted, the brake disc is meshed, and the modal analysis result is eventually achieved. Choose the brake disc's first four vibration frequency values and mode description for analysing the modal results. Complex mechanical structures' constructive design and structural integrity can be properly verified through the application of modal analysis. The braking system's brake disc is a key

component that contributes to noise and vibration, both of which have the potential to intensify within the system. Accelerometer placement in the regions of interest is made possible by numerical analysis, which also yields the modal shapes and resonant frequencies.

The following theories were considered in the design of the 3D model: the brake disc's material is homogeneous and isotropic; the analysis ignores the brake disc's inertia. Drag and drop modal workbench to project schematic.

- Enter required material from engineering data; (Grey Cast Iron- Table.1)
- Open geometry cell and start to 3D Modelling of the component's geometry using design modeller see Fig.5.
- Open Model cell, assign material (Grey cast iron) and complete mesh (Nodes=13795 and Elements=54388)
- Apply boundary condition which selects the fixed support as shown in Fig.6.
- Start to run and analysis the total deformation and frequency of first, second and third modes

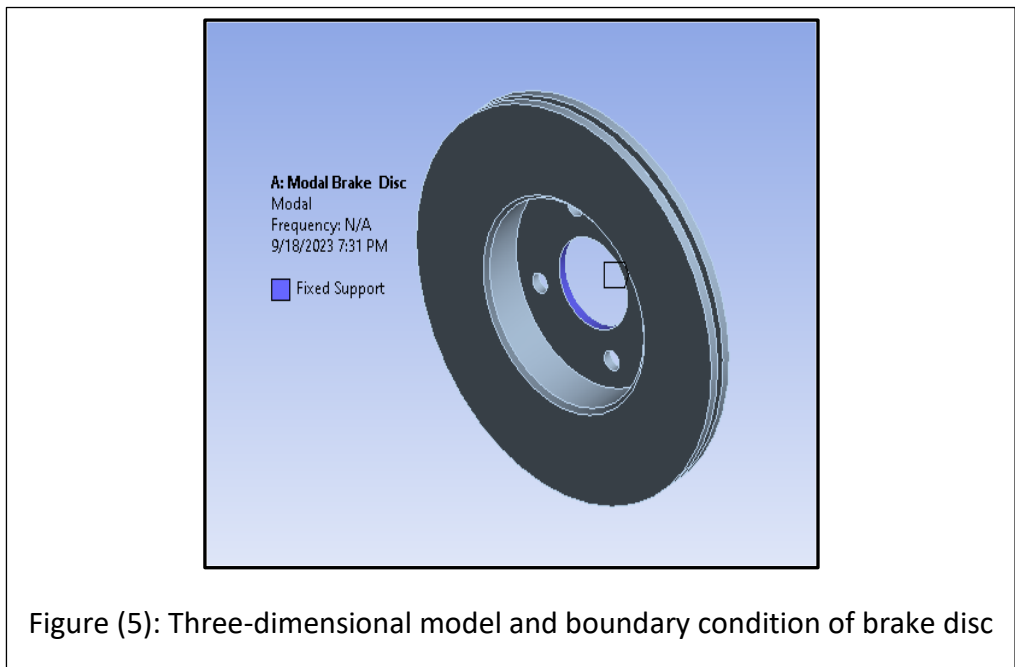

Figure (5): Three-dimensional model and boundary condition of brake disc

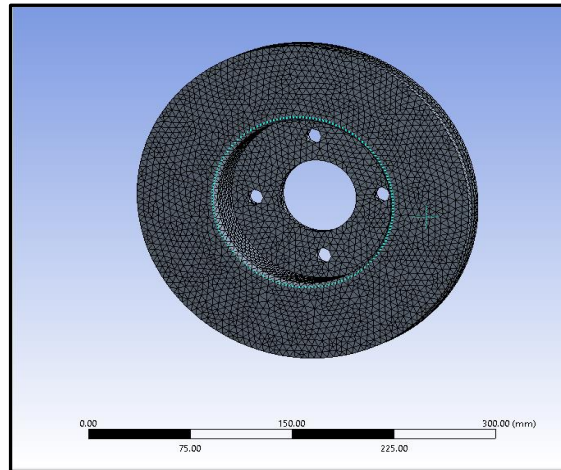

Figure (6): Meshing result

The main aim in this section is to analyse the model (mathematically description of the process varies with time; ordinary deferential equation) numerically. Moreover, comparing the results to the previous practice and theory methods described in previous sections. One method of stability in a control system is known as bode plot; which is specifies the weak states of the open loop process when subjects to a load and shows it in a peak of dome as shown in figure 7, this peak is known as resonant frequency of the process. The natural frequency in second degree model (as in this study) is approximately equal to the resonant frequency due to small value of damping coefficient c . Furthermore, the stiffness is defined from practical data of frequency and the resonant frequencies determined in bode plot analysis of stability; provided by the software, is carried out in the following steps:[13]

1. Creating the Simulink model (block diagram type) of the process as depicted in figure 7.
2. Implementing the values of the constants m , c , and k .
3. Defining the input and output signals of the open loop model.
4. Then, from a Simulink control analysis tool, the linear analysis will be selected. It is clear the model not includes the feedback loop. Since the feedback is related to the driver pressing on the brake pedal (Melons 2003) [13].
5. The bode plot code will apply for the process, and then the MATLAB Simulink creates a plot to show a resonant frequency.

The above steps will be repeated for different modes; i.e., mass reducing and gap creating between shoes and disk. Figure 7 shows the responses and highlights the resonant frequency of the model. In addition, the results data are depicted in table 2.

4. Results and Discussion

4.1 MATLAB Simulink results

Figure 7 and table 2 demonstrate a MATLAB Simulink response when tested by bode plot method of stability for different modes (changing in disk mass or increasing the air gap between shoes and disk).

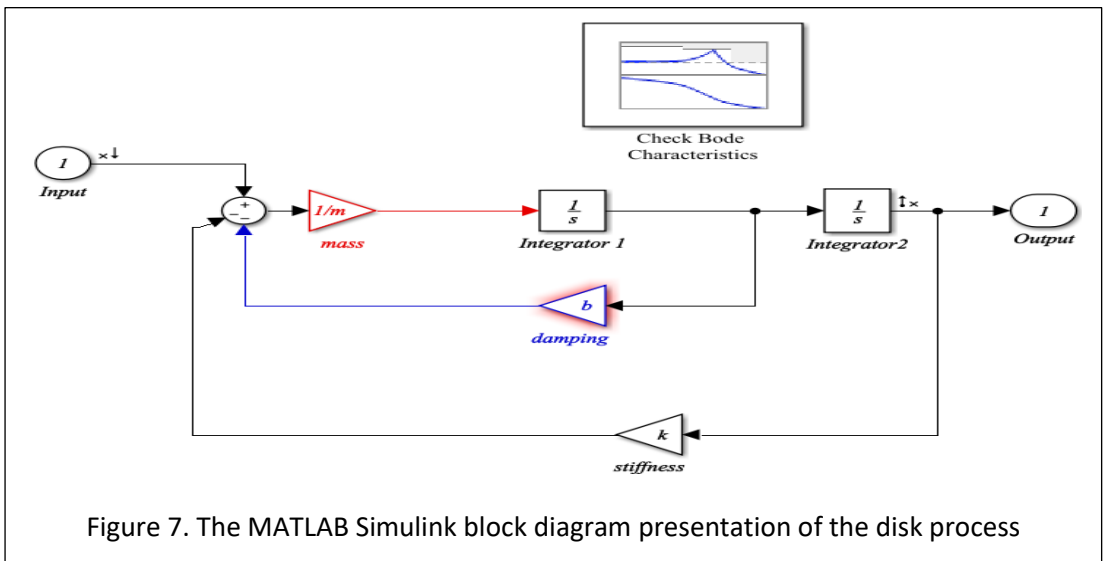

Figure 7. The MATLAB Simulink block diagram presentation of the disk process

Figure (8) is related to changing in natural frequency vs reducing brake mass, the sound will start in the vicinity of natural frequency of the process (brake). Moreover, the sound is started from the bottom of the triangles and will increase until it reaches to the triangle shape tip. Also, the figure (4) is related to the creating high sound in the range of $[f_1, f_2]$. Particularly, the sound reached to it is maximum value when the frequency is equal to natural frequency. Consequently, the vibration is at maximum (resonant) and will damage the disk brake (Saini et al 2021) [16].

The damping ratio of the system is too small; where practically is 0.0032 table 2 and according to bode plot the resonant frequency is 3.093×10^{-7} . In this case the two frequencies are equal. Also, this small value of the damping ratio makes the process exhibits sharp peak as in figure 8. Furthermore, the model has small value of damping coefficient (c); which is 0.00657, and large value of stiffness which is revealed in table 2.

These data show the decreasing in disk mass the elastic behaviour (or stiffness) will reduce; from the data the slop between stiffness and reduction – in thickness has a slop of 4.6. Since the air gap between these parts created. Consequently, the resonant frequency reduced as the thickness decreased by a slop of 11.2. Therefore, due to the effect of creating air gap more displacements (x) required by the process [14]. Nevertheless, as presented by equation 5, the natural frequency behaves reversely with the square root of the mass and depends on the stiffness square root.

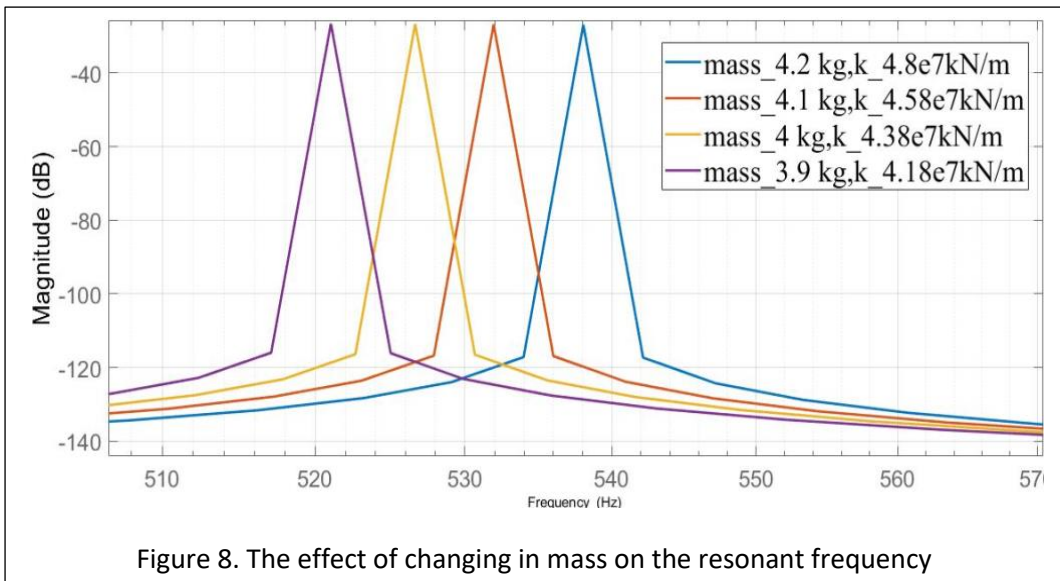

Figure 8. The effect of changing in mass on the resonant frequency

It is clear from curves of bode plot the process exhibits higher overshoots at the resonant frequency due to small value of damping coefficient c; hence small value of damping factor ζ . Consequently, high and sharp overshoot occurs (approximately 100 dB) in any transient case. In accordance to the sources of control system [13] [15] [10]

to optimize such process the damping factor ζ should be 0.707, then the damping coefficient must be 15 kN.s/m. In this case, the process exhibits smooth transient and zero overshoot (or 0 dB) as depicted in figure 9; which is optimized for mass of 4.2 kg.

4.2 Finite Element Method Results

Natural frequencies found through simulation and experimental analyses were compared in order to validate the finite element model. A comparison of Table 2's values with the resonant frequency values shows that the following values are similar: 532.27 Hz in the finite element model analysis and 538 Hz in the experiment; additionally, 523.49 Hz in the finite element model analysis and 523.49 Hz in the experiment test; furthermore 515 Hz in the finite element model analysis and 525 Hz in the experiment test; Also 507.41 Hz in the finite element model analysis (see Fig. 10 and 11) and 521 Hz in the experiment test(see Table 3). The model has therefore been almost confirmed.

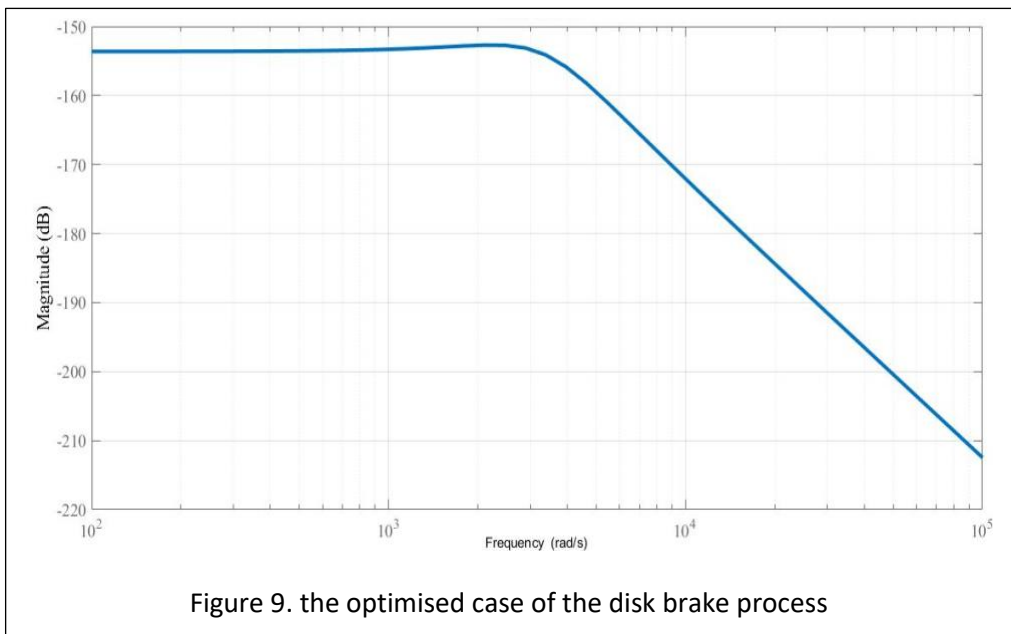

Figure 9. the optimised case of the disk brake process

Table 2. The data obtained by MATLAB Simulink

Mass modes [kg]	Resonant frequency		Stiffness k [MN/m]	Damping ratio ζ	Bode magnitude	
	[rad/sec]	[Hz]			dB	Abs.
4.2	3.38*10 ³	538	48	3.093*10 ⁻⁷	-26.9	0.045
4.1	3.34*10 ³	532	45.8	3.129*10 ⁻⁷	-26.8	0.0455
4	3.31*10 ³	527	43.8	3.16*10 ⁻⁷	-26.7	0.046
3.9	3.27*10 ³	521	41	3.194*10 ⁻⁷	-26.7	0.0465

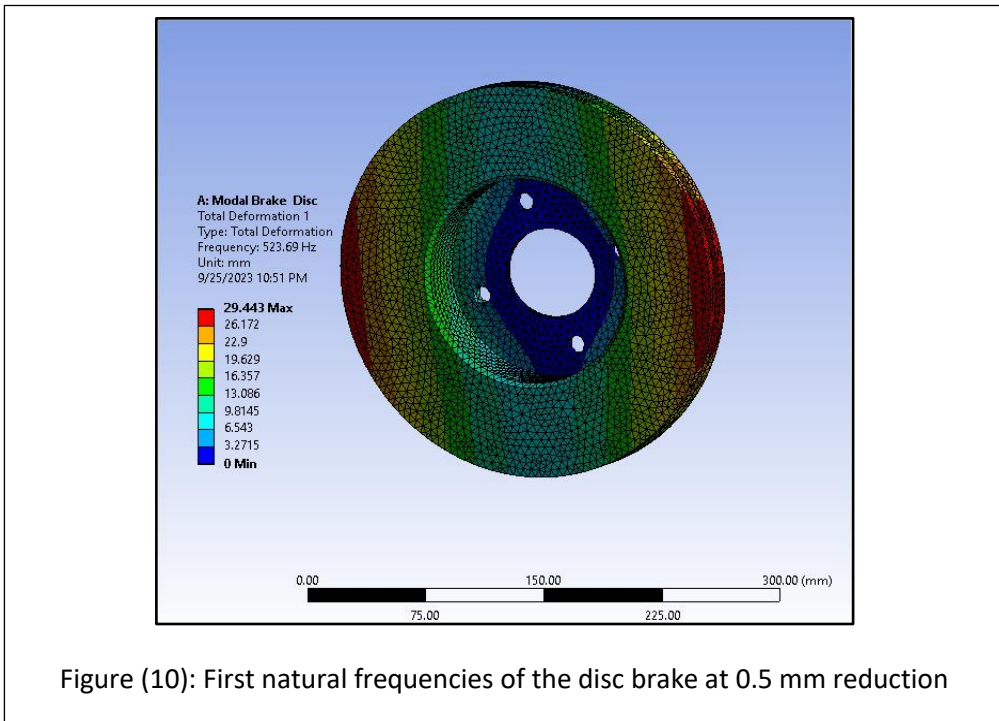

Figure (10): First natural frequencies of the disc brake at 0.5 mm reduction

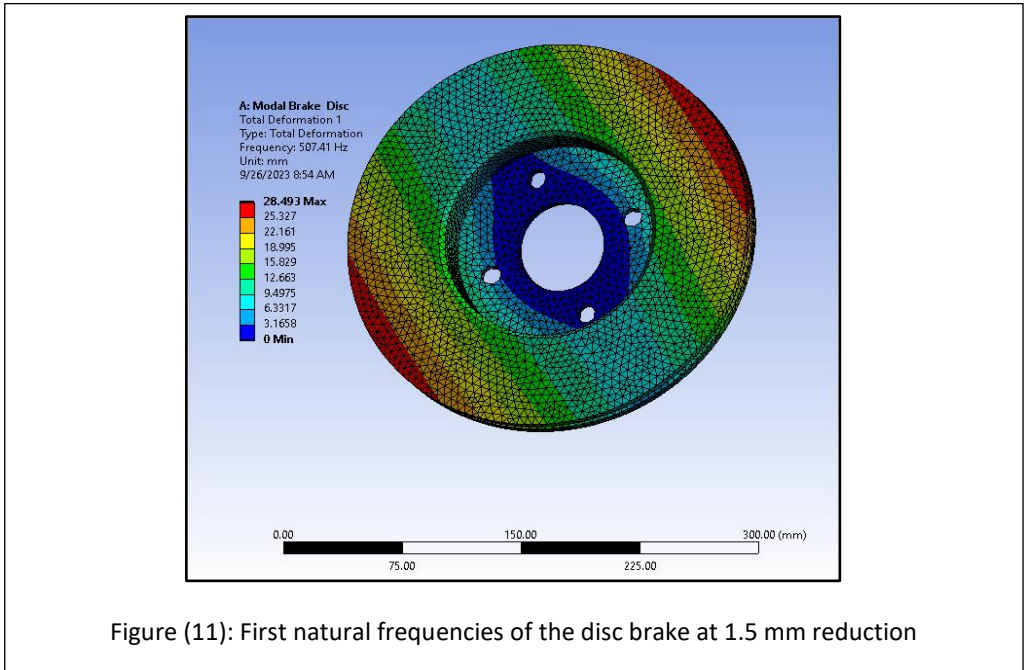

Table 3 presents the results, which indicate that the ANSYS and experimental results are quite similar when compared using MATLAB Simulink. The reason is that the mesh in ANSYS plays a major role in the accuracy of the results as well as the material specification values.

Table (3) Comparison results of natural of frequency

Thickness Reduction from original (mm)	Mass (Kg)	EMA (Hz)	ANSYS (Hz)	MATLAB Simulink (Hz)
original	4.2	538	532.27	538
0.5	4.1	533.5	523.69	532

1.0	4.0	525	515.75	527
1.5	3.9	521	507.41	521

4.3 Experimental results

An accelerometer was fixed in one of the points for each hit made with an impact hammer prior to the brake disc's analysis using a laser vibrometer. The impact hammer was used to test the disc's front portion at various points on a mesh. Figure 12 shows the data of first mode of FRF from hammer excitation, which solved using FFT analyser and the band frequency range of measurement was selected to be 532 Hz when striking the disc brake at 0.5 mm reduction, and Figure 13 shows the data of first mode of FRF from hammer excitation was 521 Hz when striking the disc brake at 1.5 mm reduction. The FRF plots clearly indicate that at certain frequencies of disc brake, the excitation input force caused brake disc structure having narrow peaks and have high value of spectrum power intensity of noise level.

The damping ratio obtain from modal data (see Table 4) indicates that the structure of disc brake exhibits relatively low damping. The damped natural frequency of a disc brake is approximately equal to the natural frequencies since the damping ratio is very small ($\ll 1$), which can be expressed as $f_n = \sqrt{1 - \zeta^2} f_d$. Originating in the field of electrical tuning, where severity of the narrow peaks of resonant peak is desirable; as the term Q-factor that determines the sharpness frequencies. The value increased along with increasing value of natural frequencies in which the damping ration becomes smaller and smaller.

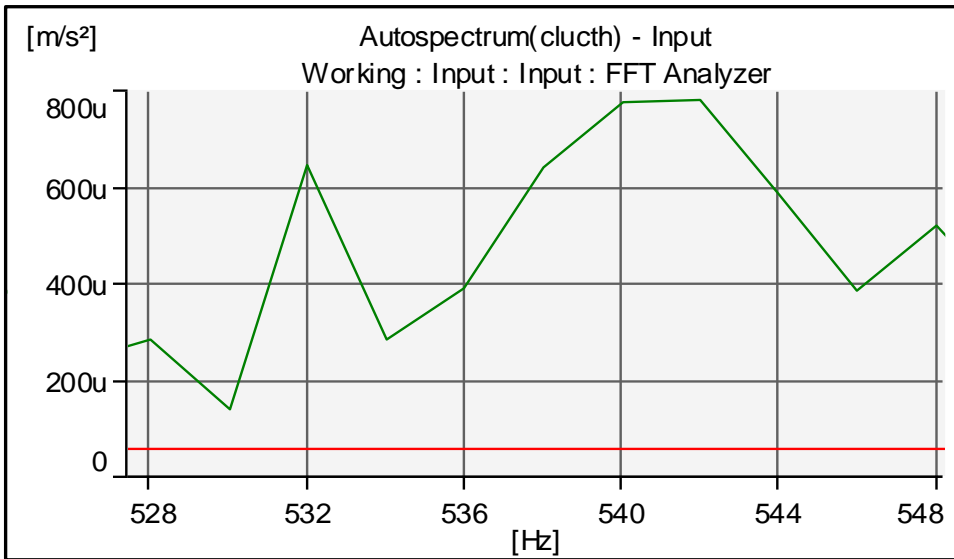

Figure (12): Frequency response function signal when striking the disc brake at 0.5 mm reduction and mass 4.1 Kg

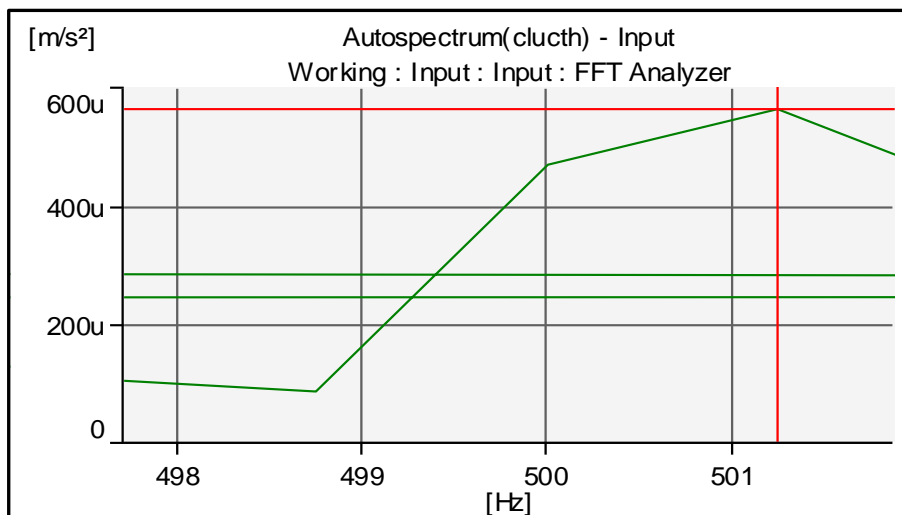

Figure (13): Frequency response function signal when striking the disc brake at 1.5 mm reduction and mass 3.9 Kg

Table (4): Results of (EMA) of brake disc for first mode

Thickness Reduction from original (mm)	Mass (Kg)	Volume (mm ³) $\times 10^{-5}$	Final thickness (mm)	Natural Freq. (Hz) f_0	Half Power point Freq. (Hz)		Loss Factor η	Damping Ratio ζ
					f_1	f_2		
original	4.2	7.0519	20	538	541	544	0.00557	0.00278
0.5	4.1	6.8403	19.5	532	530	533.5	0.0067	0.0032
1.0	4.0	6.6351	19	525	524	530	0.01142	0.00571
1.5	3.9	6.4360	18.5	521	524	527	0.01151	0.00578

5 Conclusion

By comparing the different results obtained from Finite Element Analysis (FEA), MATLAB Simulink and experimental setup, it can be concluded that;

1. According to the experimental analysis, natural frequencies and stationary rotor modes have an impact on the vibration frequencies of a squealing disc brake's rotor. As a result, brake squeal happens close to the disc's natural frequencies.
2. The measurements on the experimental disc brake structure were made using an impact hammer test to validate the computational modelling, then greater assurance could be gained from the finite element model results.
3. In accordance to MATLAB Simulink, due to generating the air gap between shoes and disk the stiffness k of the process reduced and more output distance

x required for same previous state. This effect led the resonant frequency of the process decrease as well as stiffness.

شیکاری تاقیکاری و ژمارهیی بۆ هه‌لسوکه‌وتی مۆدالی دیسکی راگرتن

پوخته :

له رووی لیکۆلینه‌وه‌یتاقیکاری:

1- له‌رینه‌وه‌ی ده‌نگده‌رکردنی پرۆسه‌ی دیسکی راگرتنی ئۆتۆمۆبیل کاریگه‌رده‌یی به‌ له‌رینه‌وه‌ی سروشتی پرۆسه‌که‌ و شیوازی راه‌ستانی پارچه‌ خولاره‌کان. ده‌نگده‌رکردن له‌م پارچه‌یه‌ رووده‌دات له‌ نزیک‌ی له‌رینه‌وه‌ی سروشتیه‌که‌ی.

2- بۆ زیاتر دلتیابوون ئەنجامه‌کانی finite element model ده‌توانریت پشقی پیننه‌سرتیت ئەگه‌ر پێوانه‌کان له‌سه‌ر دیسکی راگرتن به‌کرداری بکری به‌ به‌کار هێنانی تاقیکردنه‌وه‌ی چه‌کوچی له‌ناکاو بۆ پ‌پشتکردنی شیکاریه‌ کۆمپیوتهریه‌کان.

3- هه‌روه‌ها، به‌ ناکاره‌ییانی ماتلاب ده‌رده‌که‌وی به‌هۆی دروستبوونی بۆشایی هه‌وا له‌نیوان دیسک و راگه‌که‌ی به‌رگری سپرینگی (k) ی دیسکه‌که‌ که‌م ده‌بێته‌وه‌ ئەو کات پ‌یوستی به‌ پ‌الیه‌نانه‌ییکی (X) زیاتر ده‌نیت بۆ دۆخیک‌ پ‌ش ئەوه‌ی بگاته‌ ده‌نگده‌رکردن. ئەم کاریگه‌ریش ده‌بێته‌ هۆی که‌مبوونه‌وه‌ی له‌رینه‌وه‌ی سروشتی کرداره‌که‌ (دیسکه‌که‌) به‌هۆی که‌مبوونه‌وه‌ی به‌رگری سپرینگی.

الملخص: التحليل التجريبي والرقمي للسلوك النموذجي لقرص الفرامل

من خلال البحث التجريبي،

- 1- تتأثر ترددات اهتزاز دوار الفرامل القرصية الصرير بالترددات الطبيعية وأنماط الدوار الثابت. وبالتالي، يحدث صرير الفرامل في محيط الترددات الطبيعية للقرص.
- 2- وللتأكد من النتائج تم استخدام Finite Element Model نموذج العناصر المحدودة وذلك من خلال إجراء القياسات المأخوذة على الهيكل الحقيقي لفرامل القرص باستخدام اختبار المطرقة التصادمية للتحقق من صحة النمذجة الحسابية.
- 3- بسبب توليد فجوة الهواء بين المكبح والقرص، تم تقليل صلابة العملية k وزيادة مسافة الإخراج x المطلوبة لنفس الحالة السابقة. أدى هذا التأثير إلى انخفاض تردد الرنين للعملية وكذلك الصلابة.

LIST OF SYMBOLS

ζ	Viscous damping ratio
f_n	Natural frequency (Hz)
w_n	Natural frequency (rad/sec)
f_d	damping frequency(Hz)
Q	Quality factor
3dB	Half power points
m	mass (Kg)
ρ	Density (Kg/m ³)
η	Loss Factor
Q	Amplification factor (magnitude)
k	Spring stiffness (MN/m)
c	Damping coefficient
F	Friction force (N)

References

- [1] A. Shahril, R. Samin, J. Juraidi, and J. Daut, “Structural analysis of brake disc using dynamic simulation,” *ARNP J Eng Appl Sci*, vol. 10, no. 17, pp. 7805–7808, 2015.
- [2] M. T. Junior, S. N. Gerges, and R. Jordan, “Analysis of brake squeal noise using the finite element method: a parametric study,” *Appl. Acoust.*, vol. 69, no. 2, pp. 147–162, 2008.
- [3] V. Milovs, “Computer simulation of automotive disc brake noise,” 2003.
- [4] N. K. Kharate and S. S. Chaudhari, “Investigation of natural frequency and modal analysis of brake rotor using FEA and EMA,” vol. 3, pp. 16495–16500, 2014.
- [5] S.-W. Kung, K. B. Dunlap, and R. S. Ballinger, “Complex eigenvalue analysis for reducing low frequency brake squeal,” *SAE Trans.*, pp. 559–565, 2000.
- [6] A. Papinniemi, “Vibro-acoustic studies of brake squeal noise,” 2008.
- [7] N. M. Ghazaly, S. Mohammed, and A. M. Abd-El-Tawwab, “Understanding mode-coupling mechanism of brake squeal using finite element analysis,” *Int. J. Eng. Res. Appl.*, vol. 2, no. 1, pp. 241–250, 2012.
- [8] H. Marschner, D. Reckwerth, and H. Steger, “Innovative vibration measurement technology for brake development,” *ATZ Worldw.*, vol. 110, no. 2, pp. 18–24, 2008.
- [9] A. A. Iordache, G. Anghelache, and R. Moiescu, “Brake disc modal behaviour,” *Univ. Pitesti Sci. Bull.-Automot. Ser.*, vol. 28, no. 1, 2018.
- [10] C. W. De Silva, *Vibration: fundamentals and practice*. CRC press, 2006.
- [11] G. G. Adams, “Critical speeds for a flexible spinning disk,” *Int. J. Mech. Sci.*, vol. 29, no. 8, pp. 525–531, 1987.
- [12] D.-I. R. Baumert, D.-I. J. Porbeck, and S. Szajstek, “Auftraggeber: Hagedorn Revital GmbH Werner-von-Siemens-Straße 18 33334 Gütersloh”.
- [13] O. Katsuhiko, *Modern control engineering*. Editorial Félix Varela, 2009.
- [14] Truls Edvardsen Aarønes 2015. “Study of the Natural Frequencies of a Disc”. MSc Thesis, Department of Energy and Process Engineering, Norwegian University of Science and Technology
- [15] H. M. Omar, “Enhancing automatic control learning through Arduino-based projects,” *Eur. J. Eng. Educ.*, vol. 43, no. 5, pp. 652–663, 2018.
- [16] Saini, M. K., Bagha, A. K., Kumar, S., & Bahl, S. (2021). Finite element analysis for predicting the vibration characteristics of natural fiber reinforced epoxy composites. *Materials Today: Proceedings*, 41, 223-227.