



# Course Book

<b>1. Course name</b>	Applied Electronics
<b>2. Lecturer in charge</b>	Dr. Khalid A. Abbas
<b>3. Department/ College</b>	College of Science, Physics Department
<b>4. Contact</b>	E-mail <a href="mailto:khalid.abbas@su.edu.krd">khalid.abbas@su.edu.krd</a>
<b>5. Time (in hours) per week</b>	Theory: 3.0 (Three only) Practical: 12
<b>6. Office hours</b>	At least 5 h/week
<b>7. Course code</b>	
<b>8. Teacher's academic profile</b>	<p>I studied for an undergraduate degree in Physics science at Salahaddin University- Erbil between the years of 1982- 1986.</p> <p>I obtained MSc in Nuclear Physics in 1991. In 1992, I got a position in Salahaddin University as a laboratory supervisor (Thermodynamics, general physics lab. ).</p> <p>In 2008 I obtained Ph.D. and now I lecture the subject “Applied Electronic” for the third grad physics students.</p>
<b>9. Keywords</b>	Applied electronics, electronic circuits.
<b>10. Course overview:</b>	This course presents an overview of the fundamentals of electronic circuit application, starting with an overview of electronic components then application.
<b>11. Course objective:</b>	The objective of applied electronic is to introduce basic principles of applied electronics. Starting from basic components to circuits.
<b>12. Student's obligation</b>	Normally, students obliged to attend all the lectures and take notes during the lecture. In addition, in class participation would be a bonus of the students to widen their knowledge

and understand the module thoroughly. Attending the lectures regularly would be a crucial point for the students to consider, because the module is very new and very detailed. If the students missed few lectures, they would have difficulty to get back on the track.

Additionally, students are ought to submit and their home works and assignments given by their lecturer, because there would be penalties for the late submission. All exams and tests done with books closed, and, students have to take at least two compulsory exams with few class test and quizzes during the years of study.

### **13. Forms of teaching**

I am using some ways to make the students engage with the lecture like power point slides explanation view, white bard in the class and animations to explain the theory of the subject and then the students also must give attention to the explanation in the class. If there were slides that needed more explanation the rest, or, if the slide needed a long, explanation and I thought that the students must know all of that, I would distribute the printed out version of the description on the students to widen their knowledge on the subject.

### **14. Assessment scheme**

Three monthly examination	30 %
For each chapter one Quiz	10%
Final examination	60%

### **15. Student learning outcome:**

Students who took the lectures of electronic would easily be able to use and maintenance of electronic devices and learn the principles used in all areas of electronics.

### **16. Course Reading List and References:**

The main text books are:

#### **1. Practical Electronic for inventors, By: Paul Scherz 2000.**

<b>2. Electronic Device and circuit theory, By R. Boylestand and L. Nashelsky, 7<sup>th</sup> ed.</b>	
<b>17. The Topics:</b>	<b>Lecturer's name</b>
<p><b>Week1, 2, and 3: CH1: General Introduction to Semiconductor Physics</b></p> <p>1.1- Energy band in Solid:            1.2- Conductors, Insulators and Semiconductors:            1.3- Atomic Binding in Semiconductors            1.4- Types of Semiconductors            1.5- PN-junction            1.6- IV- Characteristic for PN-junction diode</p> <p><b><u>Week4, 5, 6 and 7:</u> CH2: Bipolar Junction Transistor</b></p> <p>2.1 Introduction            2.2 Important Biasing rules            2.3 Transistor Currents components            2.4 CB Configuration            2.5 Transistor Static Characteristics            2.6 Common Base Static Characteristics            2.7 CE Configuration            2.8 Common Emitter Test Circuit            2.9 CC Configuration            2.10 BJT Formula.            2.11 Solve problem.</p> <p><b><u>Week8, 9, 10, 11 and 12:</u> CH3: Load lines and DC Bias circuit</b></p> <p>3.1- Important of <math>V_{CE}</math>:            3.2- D.C. Load Line            3.3- BJT Switches (at cutoff and saturation region)            3.4- Notation for Voltages and Currents            3.5- Transistor AC/DC Analysis            3.6- D.C load Line (Active Region)            3.7- Quiescent Point            3.8- Load Line and Output characteristic            3.9- AC Load Line            3.10- Temperature affecting bias variations            3.11- Stability Factor            3.12- Different Methods for Transistor Biasing            3.13- Solve problem</p> <p style="text-align: center;"><b><u>Week13, and 14:</u> CH4: Darlington Transistors</b></p> <p>4.1 Darlington Transistors            4.2 Some application            4.3 Solve problem</p> <p style="text-align: center;"><b>Week 15: first Exam</b></p>	<p><b>Dr. Khalid</b>  <b>Length: 3 hours</b>  <b>per week</b></p>

**Week16, 17 and 18: CH5: TRANSISTOR EQUIVALENT CIRCUIT AND MODELS**

- 5.1- Introduction:
- 5.2- Amplification in the AC domain
- 5.3 The BJT as an Amplifier and the important parameter ( $Z_i$ ,  $Z_o$ ,  $A_v$ ,  $A_i$ ).
- 5.4 The transistor re model:
- 5.5 The hyper equivalent circuit

**Week19, 20, 21 and 22: CH6: TRANSISTOR EQUIVALENT CIRCUIT AND MODELS**

- 6.1 The Field Effect Transistor (JFET) physical principles
- 6.2 Static Characteristics of JFET
- 6.3 Common source
- 6.4 Common Drain
- 6.5 FET as a switch and an amplifier
- 6.6 Solve problem

**Week23, 24, and 25: CH7: Operational Amplifier**

- 7.1 Operational Amplifier Op Amp
- 7.2 Equation of Op Amp
- 7.3 The inverting
- 7.4 Non-inverting,
- 7.5 Summing,
- 7.6 Integrating,
- 7.7 Schmidt trigger amplifier

**Week 26, 27, 28 and 29,: CH8: Digital Electronic**

- 8.1 The binary number system
- 8.2 Digital electronic and some medical application

**Exam: week 30**

**19. Examinations:**

**A sample:**

**Q.1: Chose the correct answer: (10Mark)**

- 1. Conduction electrons have more mobility than holes because they
  - (a) Are lighter.
  - (b) Experience collisions less frequently
  - (c) Have negative charge.



**Q4:** In a simple amplifier circuit (Fig. 1) with base resistance,  $R_B = 50\text{ K}$ ,  $R_E = 2\text{ K}$ ,  $R_C = 3\text{ K}$ ,  $V_{CC} = 10\text{ V}$ ,  $\beta = 100$ , determine whether or not the silicon transistor is in the saturation.

(20 Mark)

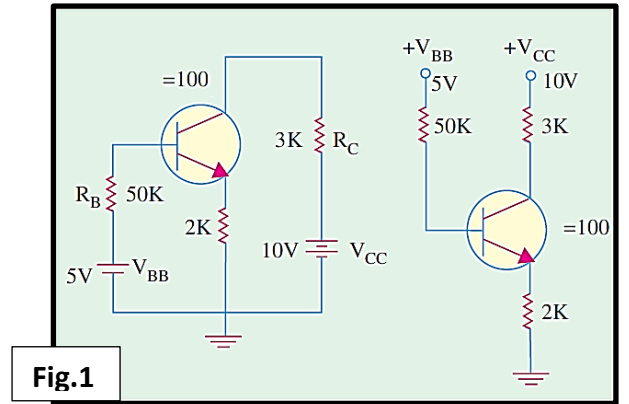

Fig.1

**Q5-A:** Given the load line of (Fig. 2) and the defined  $Q$ -point for insert circuit, determine the required values of  $V_{CC}$ ,  $R_L$ , and  $R_B$  for a fixed-bias configuration.

(15 Mark)

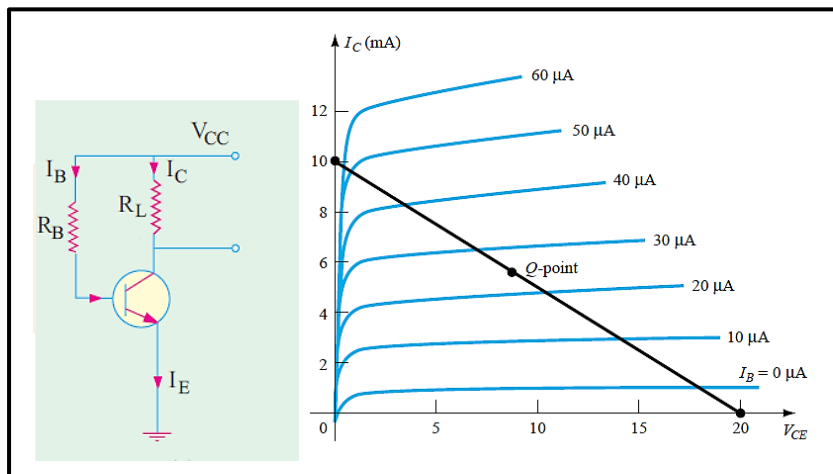
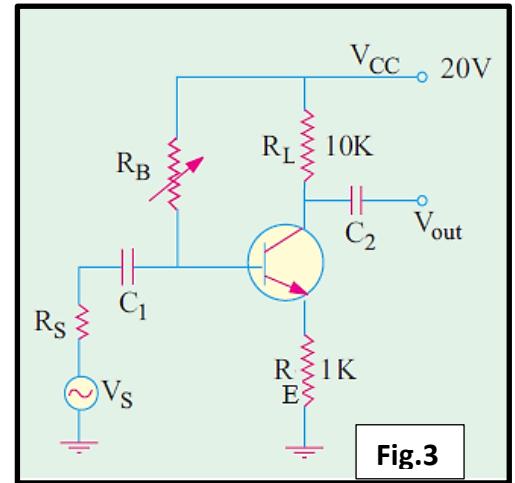

Fig.2

Q5-B: Determine the value of  $R_B$  required adjusting the circuit of (Fig. 3) optimum operating point (Q-point). Take  $\beta = 50$  and  $V_{BE} = 0.7 V$ .

(15Mark)



Good Luck

Lecturer  
Dr. Khalid A. Abbas

20. Extra notes:

-----

21. Peer review