



Department of Physics
College of Science
University of Salahaddin

Analog Electronics

Bsc. Degree in Applied Physics (communication Branch)

Academic Year: 2022/2023

Lecturer: Dr. Lary Hana Slewa

Email: lary.slewa@su.edu.krd

Course Book

1. Course name	Analog Electronics
2. Lecturer in charge	Dr. Lary Hana Slewa
3. Department/ College	College of Science, Physics Department
4. Contact	E-mail: lary.slewa@su.edu.krd
5. Time (in hours) per week	Theory: 3.0 (Three only) Practical: 0
6. Office hours	At least 10 h/week
7. Course code	SPh
8. Teacher's academic profile	<p>I studied for an undergraduate degree in Physics science at Salahaddin University- Erbil between the years of 2001- 2005. After graduation in 2005, in the same year, I got a position in Salahaddin University as a laboratory demonstrator (general physics lab. , optics lab. , Electric lab and Electric measurement lab). I stayed with the job for more than 9 year. In 2014, I obtained MSc in thin film.</p> <p>3/12/2014 Assistance Lecturer in University of Salahaddin- College of science physics department - Erbil -Iraq</p> <p>For academic year 2016-2017 I've taught Electronic in Medicine for third year Physics student in Physic department .</p> <p>Finally, I have obtained PhD. degree in Solid state (Nanotechnology for biochemical application) from Salahaddin University-Erbil, Kurdistan Region, Iraq, through split site program with Universiti Sains Malaysia. I have published 11 research papers in scientific journals. I'm interest in nanomaterials fabrication and characterization by using chemical and physical technology, where I have used films in many applications, such as solar cell, gas, optoelectronics, thin film EGFET for pH</p>

	sensors, and multilayer characteristics, etc...
9. Keywords	N/A
10. Course overview:	
<p>This course presents an overview of the fundamentals of electric/electronic circuit analysis, starting with an overview of electrical theory and moving to simple circuit components like diode, transistor, and operation amplifier.</p>	
11. Course objective:	
<p>The objective of applied electronic is to make student to be introduced to the principle of applied electronic to be familiar with the operation of basic electronic circuits used in modern technology especially in two branches; communication and medical physics, and presenting information as it may relate to a specific measurement problem or instrument. This Academic year will cover the main principles and applications of electronics in almost all fields of applied physics.</p>	
12. Student's obligation	
<p>Normally, students obliged to attend all the lectures and take notes during the lecture. In addition, in class participation would be a bonus of the students to widen their knowledge and understand the module thoroughly. Attending the lectures regularly would be a crucial point for the students to consider, because the module is very new and very detailed. If the students missed few lectures, they would have difficulty to get back on the track.</p> <p>Additionally, students are ought to submit and their home works and assignments given by their lecturer, because there would be penalties for the late submission. All exams and tests done with books closed, and, students have to take at least two compulsory exams with few class test and quizzes during the years of study.</p>	
13. Forms of teaching	
<p>I am using some ways to make the students engage with the lecture like power point slides explanation view, white bard in the class and animations to explain the theory of the subject and then the students also must give attention to the explanation in the class. If there were slides that needed more</p>	

explanation the rest, or, if the slide needed a long, explanation and I thought that the students must know all of that, I would distribute the printed out version of the description on the students to widen their knowledge on the subject.

14. Assessment scheme

Three monthly examination	30 %
For each chapter one Quiz	10%
Final examination	60%

15. Student learning outcome:

Students who took the lectures of electronic would easily be able to Ease of use and maintenance of electronic devices and learn the principles used in all areas of the job

16. Course Reading List and References:

The main text books are:

1. **Solid State Electronic Devices, By: Ben G. Streetman, 3rd edition, 2014.**
2. **Electronic Device and circuit theory, By R. Boylestand and L. Nashelsky, 7th edition.**
3. **Electronic Devices & Circuits, by Jacob Millman & Christos C. Halkias, 1967.**

17. The Topics:

Lecturer's name

Week1, 2, and 3: CH1: General Introduction to Semiconductor Physics

Dr. Lary Hana
Slewa
Length: 3 hours
per week

- 1.1- Energy band in Solid:
- 1.2- Conductors, Insulators and Semiconductors:
- 1.3- Atomic Binding in Semiconductors
- 1.4- Types of Semiconductors
- 1.5- PN-junction
- 1.6- IV- Characteristic for PN-junction diode

Week4, 5, 6 and 7: CH2: Bipolar Junction Transistor

- 2.1 Introduction
- 2.2 Important Biasing rules
- 2.3 Transistor Currents components
- 2.4 CB Configuration
- 2.5 Transistor Static Characteristics
- 2.6 Common Base Static Characteristics

2.7 CE Configuration

2.8 Common Emitter Test Circuit

2.9 CC Configuration

3.10 BJT Formula.

2.11 Solve problem.

Week8, 9, 10, 11 and 12:

CH3: Load lines and DC Bias circuit

3.1- Important of V_{CE} :

3.2- D.C. Load Line

3.3- BJT Switches (at cutoff and saturation region)

3.4- Notation for Voltages and Currents

3.5- Transistor AC/DC Analysis

3.6- D.C load Line (Active Region)

3.7- Quiescent Point

3.8- Load Line and Output characteristic

3.9- AC Load Line

3.10- Temperature affecting bias variations

3.11- Stability Factor

3.12- Different Methods for Transistor Biasing

3.13- Solve problem

Week13, and 14:

CH4: Darlington Transistors

4.1 Darlington Transistors

4.2 Some application

4.3 Solve problem

Week 15: first Exam

Week16, 17 and 18: CH5: TRANSISTOR EQUIVALENT CIRCUIT AND MODELS

5.1- Introduction:

5.2- Amplification in the AC domain

5.3 The BJT as an Amplifier and the important parameter (Z_i , Z_o , A_v , A_i).

5.4 The transistor re model:

5.5 The hyper equivalent circuit

Week19, 20, 21 and 22: CH6: TRANSISTOR EQUIVALENT CIRCUIT AND MODELS

6.1 The Field Effect Transistor (JFET) physical principles

6.2 Static Characteristics of JFET

6.3 Common source

6.4 Common Drain

6.5 FET as a switch and an amplifier

6.6 Solve problem

Week23, 24, and 25: CH7: Operational Amplifier

7.1 Operational Amplifier OpAmp

7.2 Equation of OpAmp

7.3 The inverting

7.4 Non-inverting,

7.5 Summing,

7.6 Integrating,

7.7 Schmidt trigger amplifier

Week 26, 27, 28 and 29,: CH8: Digital Electronic

8.1 The binary number system

8.2 Digital electronic

8.3 Logic gates

Exam: week 30

19. Examinations:

A sample:

Q.1: Chose the correct answer: (10Mark)

1. Conduction electrons have more mobility than holes because they
 - (a) Are lighter.
 - (b) Experience collisions less frequently
 - (c) Have negative charge.
 - (d) Need less energy to move them.
2. When a $P-N$ junction is formed, diffusion current causes
 - (a) Barrier potential.
 - (b) Mixing of current carriers
 - (c) Forward bias
 - (d) Reverse bias.
3. For current working of an NPN - BJT, the different electrodes should have the following polarities with respect to emitter.
 - (a) Collector +ve, base -ve
 - (b) Collector -ve, base + ve
 - (c) Collector - ve, base -ve
 - (d) Collector + ve, base +ve
4. The value of total collector current in a CB -configuration circuit is

- (a) $I_C = \alpha I_E$
- (b) $I_C = \alpha I_E + I_{CBO}$
- (c) $I_C = \alpha I_E - I_{CBO}$
- (d) $I_C = \alpha I_E + I_{CEO}$

5. Early-effect in BJT refers to

- (a) Junction break down
- (b) Thermal break down
- (c) Base narrowing
- (d) Zener break-down

Q2: Give the reason behind: (20 Mark)

- 1- Two diodes cannot take place or work as a BJT.
- 2- We don't need to change the polarity of bias battery for CE –BJT circuit to change the mode of the transistor from active to saturation.
- 3- The different phase between input and out AC voltage for CE –amplifier
- 4- The best location of the Q point it's in the middle of the load line.

Q3: For a certain transistor, $I_C = 5.505 \text{ mA}$, $I_B = 50 \mu\text{A}$, $I_{CBO} = 5 \mu\text{A}$. Determine:

- (i) Values of α , β and I_E
- (ii) The new level of I_B required to make $I_C = 10 \text{ mA}$. (20 Mark)

Q4: In a simple amplifier circuit (Fig. 1) with base resistance, $R_B = 50 \text{ K}$, $R_E = 2 \text{ K}$, $R_C = 3 \text{ K}$, $V_{CC} = 10 \text{ V}$, $\beta = 100$, determine whether or not the silicon transistor is in the saturation.

(20 Mark)

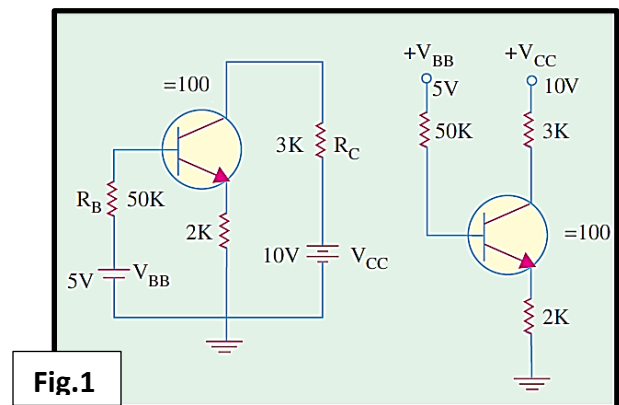

Q5: Given the load line of (Fig. 2) and the defined Q-point for insert circuit, determine the required values of V_{CC} , R_L , and R_B for a fixed-bias configuration.

(15 Mark)

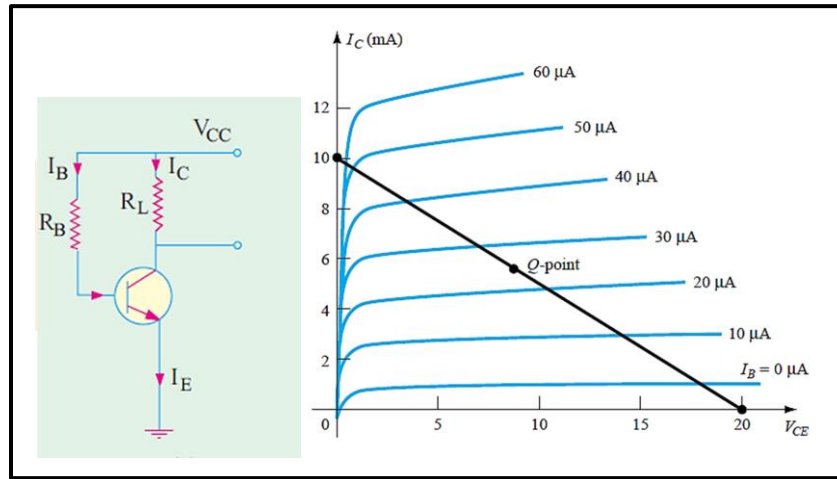

Fig.2

Good Luck

Lecturer
Dr. Lary H. Slewa

20. Extra notes:

21. Peer review

I am MSc Shaida Anwer Kakil, I confirm that I reviewed lary's course content and course book structure. I found his work very interesting; I thinks students will be lucky to have this kind of module in their BSc degree. I had few suggestions of the works, and he warmly welcomed my suggestions. Hope him all the best.