



Department of Environmental Science and Health

College of Science

University of Salahaddin

Subject: Environmental Engineering-Practical

Course Book (3rd Year)

Lecturer's name: MSc. Nihal Suhail Hanna

Academic Year: 2022-2023

Course Book

| | |
|--------------------------------------|--|
| 1. Course name | Environmental Engineering (Practical) |
| 2. Lecturer in charge | Nihal S. Hanna |
| 3. Department/ College | Environmental Science and Health/Science |
| 4. Contact | e-mail: nihal.hanna@su.edu.krd Tel: (optional) |
| 5. Time (in hours) per week | Practical: 2 hours per week |
| 6. Office hours | 6 hours per week |
| 7. Course code | |
| 8. Teacher's academic profile | <ul style="list-style-type: none"> • I graduate from Salahaddin University in 2012 (Ranked 1st in Environmental sciences department). In 2015 I finished M.Sc degree in water quality and pollution (aquatic insect as bioindicator). Finally, I became lecturer assistant in 2016. • I published 7 papers in international scientific journal. I teach under graduate student like, entomology, water quality, water pollution, engineering drawing, principles of environmental sciences, computer science and academic debate. • I worked as a member of the examination committee for college of science in (2015-2016) , (2017-2018) and (2020-2021). • I become lecturer in 12/9/2019. • Now I am a Ph.D. student in Ecotoxicity at Salahaddin University -Sciences college- Environmental health and science department. |
| 9. Keywords | Engineering Drawing, Planning and Landscaping. |
| 10. Course overview: | <p>The course offer methodology & practice in Engineering Drawing. Participant is introduced to the standard of engineering drawing applied in the environmental engineering applications. Upon completion of this course, participants will be able to:</p> <ul style="list-style-type: none"> • Explain the task and standard of Engineering Drawing. • Practice good industrial standards in Engineering Drawing. • Practical training approach toward research & development for design & engineering. |
| 11. Course objective: | |

This course involves an introductory experience in technical drawing as a tool of technical communication. Primary emphases are on development of basic drafting skills, visualization and solving graphical problems. The objective of the course is to teach students the tools and techniques for making engineering drawings. By the end of the course, students should gain the practical knowledge of engineering design drawing ability as well as comprehending architectural, electrical and mechanical drawings. The scope of the course is in two parts, which involves introduction to basics of technical drawing skills for drawing basic geometric shapes and graphical projection techniques.

12. Student's obligation

A typical class will be to start with quiz. Every student must have two examinations, the attendance and classroom activities. So that the final grade will be based upon the following criteria:

- ✓ Mean of two practical examinations: 30%
- ✓ Daily quizzes: 5%

13. Forms of teaching

Different forms of teaching will be used to reach the objectives of the course: power point presentations for the head titles, drawing steps and summary of conclusions, other illustrations, besides worksheet will be designed to let the chance for practicing on several aspects of the course in the classroom, furthermore students will be asked to prepare research papers on selective topics and summarize articles contents published in English into either Kurdish or Arabic language, those articles need to be from printed media or internet articles. There will be classroom discussions and the lecture will give enough background to translate, solve, analyze, and evaluate problems sets, and different issues discussed throughout the course.

To get the best of the course, it is suggested that you attend classes as much as possible, read the required lectures, teacher's notes regularly as all of them are foundations for the course. Lecture's notes are for supporting and not for submitting the reading material including the hand outs. Try as much as possible to participate in classroom discussions, preparing the assignments given the course given in the course.

14. Assessment scheme

Your final grade will be derived as follows:

Quizzes: About 10 quizzes will be given throughout the semester. They will be given at the end of the class.

Exams: There will be two closed book exams given throughout the semester. Each test will be scheduled for 90 minutes.

15. Student learning outcome:

by the end of the course, students should be able to:

1. Ability to relate and apply fundamental sciences to learning the essential engineering concepts and theories of different branches.
2. Ability to define clearly and analyse the engineering problems by applying the introduced engineering concepts and theories of the related branch.

3. Ability to use decision-making skills and perform design calculations correctly for the solution of the defined problem/project by applying the introduced theories of the related engineering branch.
4. Ability to participate in team-works in a harmonized manner for the solution of the targeted problem.

16. Course Reading List and References:

1. Taffesse, W. and Kassa, L. 2005. *Engineering Drawing Lecture Notes for Environmental Health Science Student*. Produced in collaboration with the Ethiopia Public Health Training Initiative, The Carter Center, the Ethiopia Ministry of Health, and the Ethiopia Ministry of Education.
2. Reddy, K. V. 2008. *Textbook of Engineering Drawing*. 2nd Edition, BS Publications. Hyderabad.

| 17. week | Topic |
|----------|--|
| 1 | An introduction to Engineering Drawing |
| 2 | Drawing equipment and their use |
| 3 | Basic principles of engineering drawing |
| 4 | Sizes and layout of Drawing Sheets |
| 5 | Engineering Drawing Operations |
| 6 | Lines |
| 7 | Drawing of Geometrical figures |
| 8 | Free hand drawing of lines, polygons, hexagons, pentagon, and octagon. |
| 9 | Free hand drawing of ellipse and angles. |
| 10 | Dimensioning |
| 11 | Projections (part 1) |

| | |
|----|------------------------------|
| 12 | Projections (part 2) |
| 13 | Messing Views (hidden lines) |
| 14 | Sectioning |
| 15 | Exam |

18. Practical Topics (If there is any)

19. Examinations:

Q1/ draw the projections of the following: (note; scale 1:1)

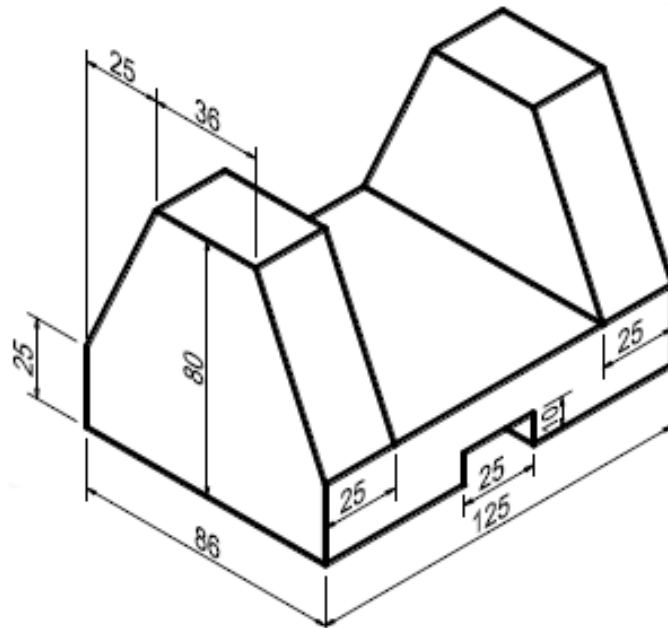

Answer key:

Note: the answer of the question is hand drawing.

20. Extra notes:

21. Peer review

پیداچوونہوہی ھاوہل