

The Component of Motel

Spring Semester

2023-2024

sardar swar

2.1) Site:

- close to transportation, commercial centres, entertainments and good view (sea or landscapes).
- Located near natural areas and landmarks.
- Far away from schools and crowded areas.
- Preferred to be overlooking on two streets.
- It is preferred 3 entrances overlooking on streets one for public 2nd for parking third for staff and goods as a site entrance.



2.2) Building Entrances:

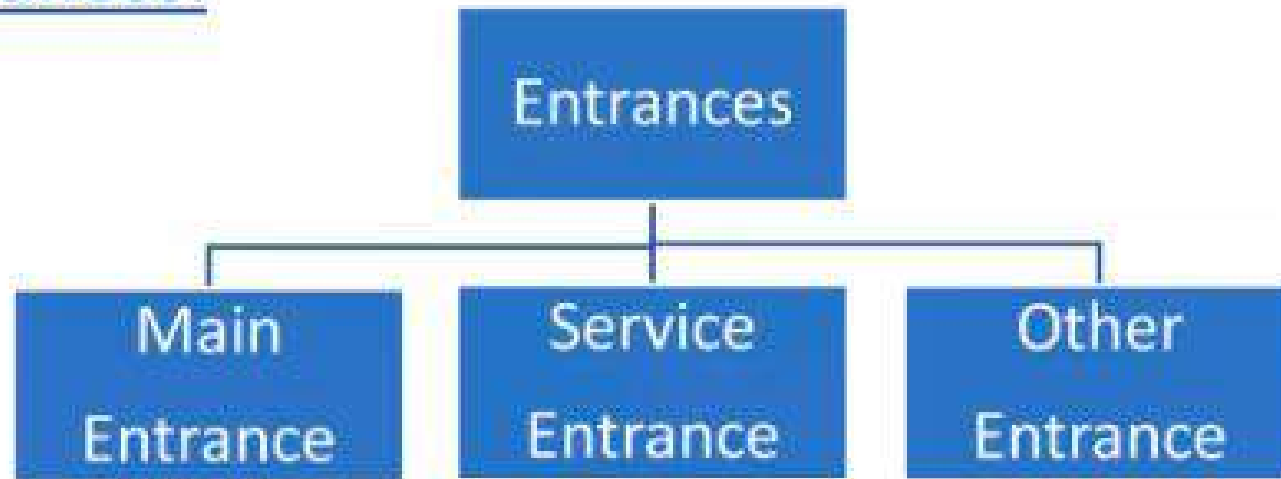

- **Main Entrance:**

- Something more than a canopy is desirable to provide protection from wind and rain.
- Special lighting may be needed to accentuate the entrance (Figure 1).
- Porte-Coehere should be wide enough to allow two cars to pass and for porter with bags, so we need 900mm clear.
- Special lighting may be needed to accentuate the entrance (Figure 1).
- Porte-Coehere should be wide enough to allow two cars to pass and for porter with bags, so we need 900mm clear.
- At least one entrance from garage must be accessible to wheel chair users.



Figure 1 public entrances

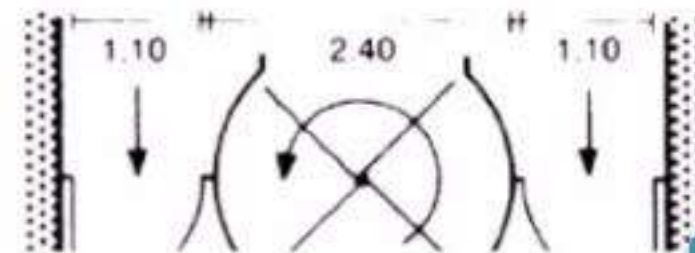

Figure 2 revolving door with extra emergency exits

- **Service entrance:**

- Access for guests and hotel servicing must be clearly separate (figure 3).
- It is normally from a road different from the main entrance.
- suitable door width for furniture (Figure 4).

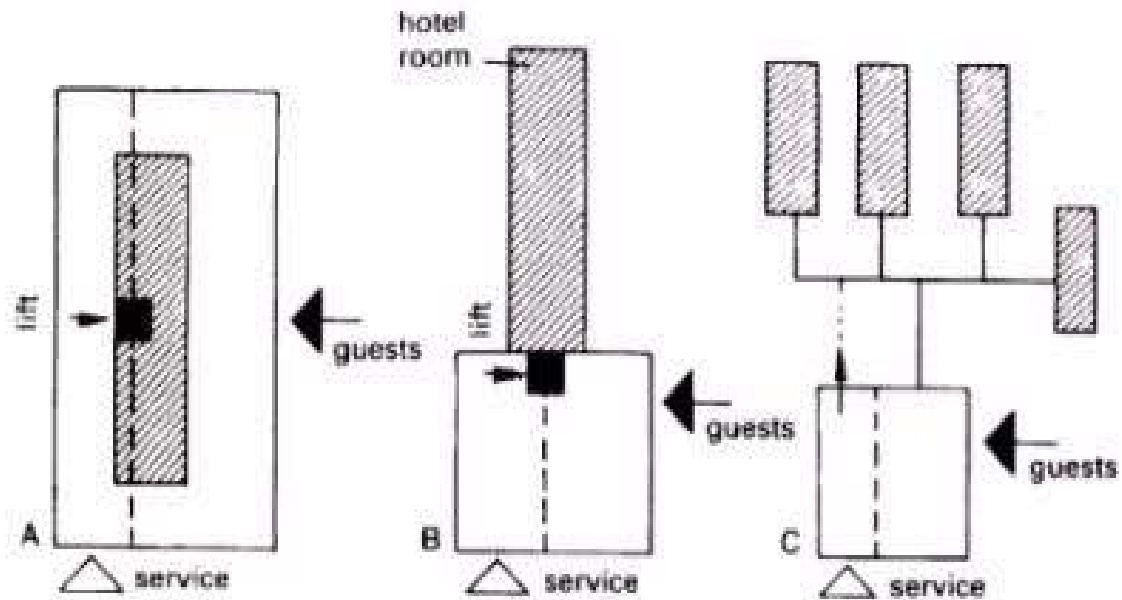

Figure 3 hotel and service entrance relations

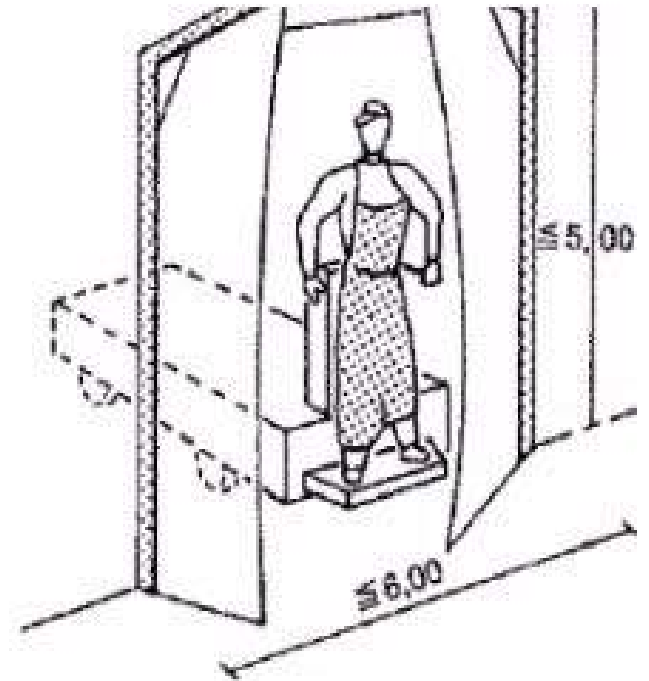
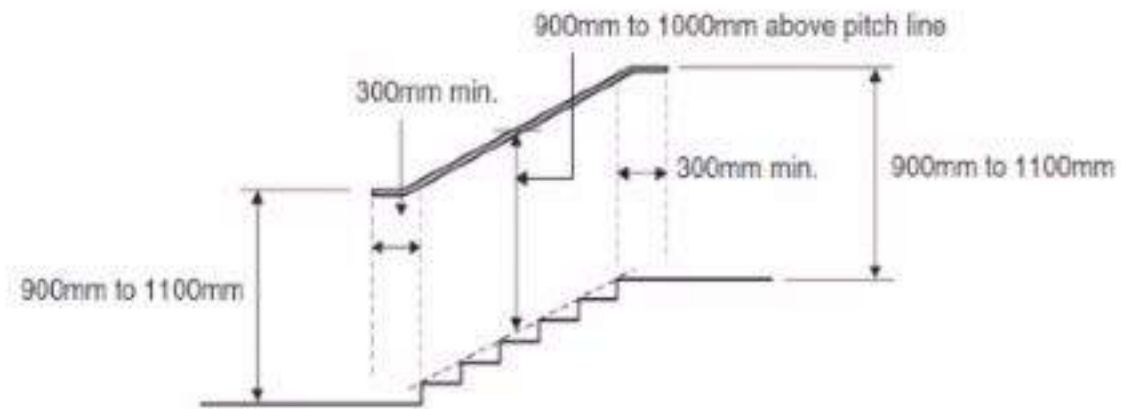
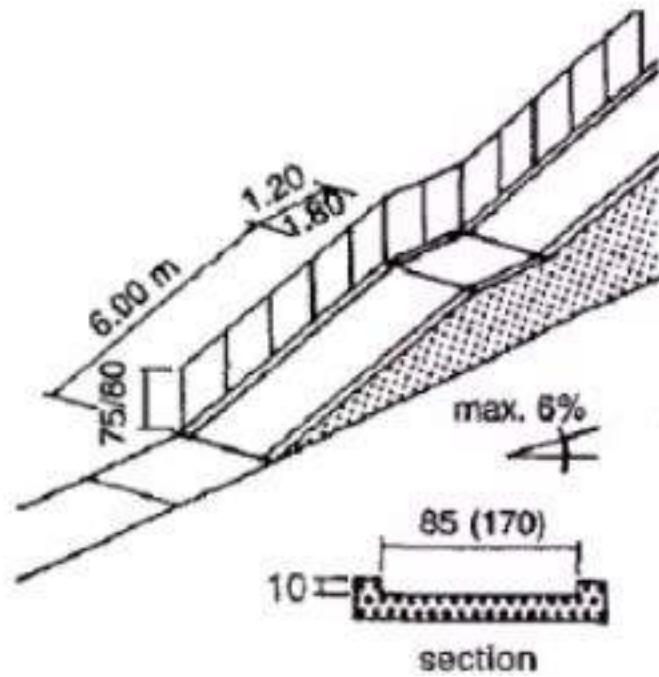

Figure 4 service door

2.3) Stairs and Ramp for main entrance:



3.2) Hotel contents:

Rooms area	Public area	Catering	Function halls	admin	Services	Building services	Others activates
50-60%	4-7%	4-8%	4-12%	1-2%	9-14%	5-10%	1-2%
Guests rooms	Public halls	Restaurant	Events hall	Management	Kitchens	Structure system	Wellness
Corridors	Waiting		ballroom	Offices	Stores	Walls	Fitness area
Room	Others		Seminar hall	Security	circulation		Pool

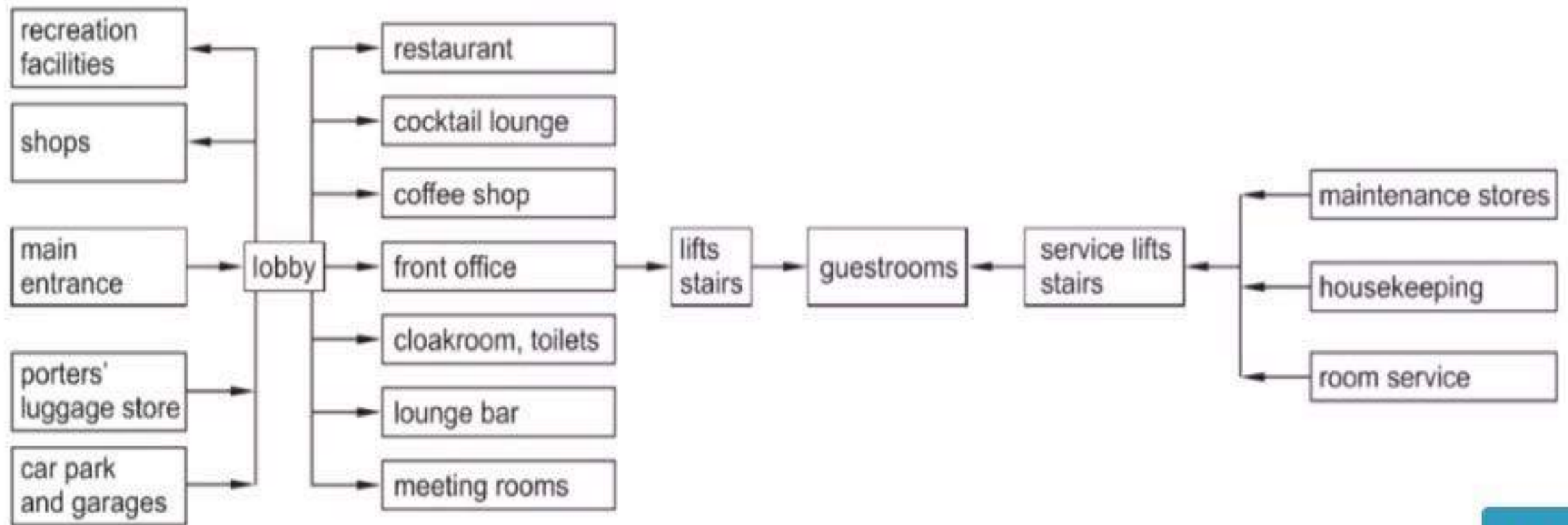
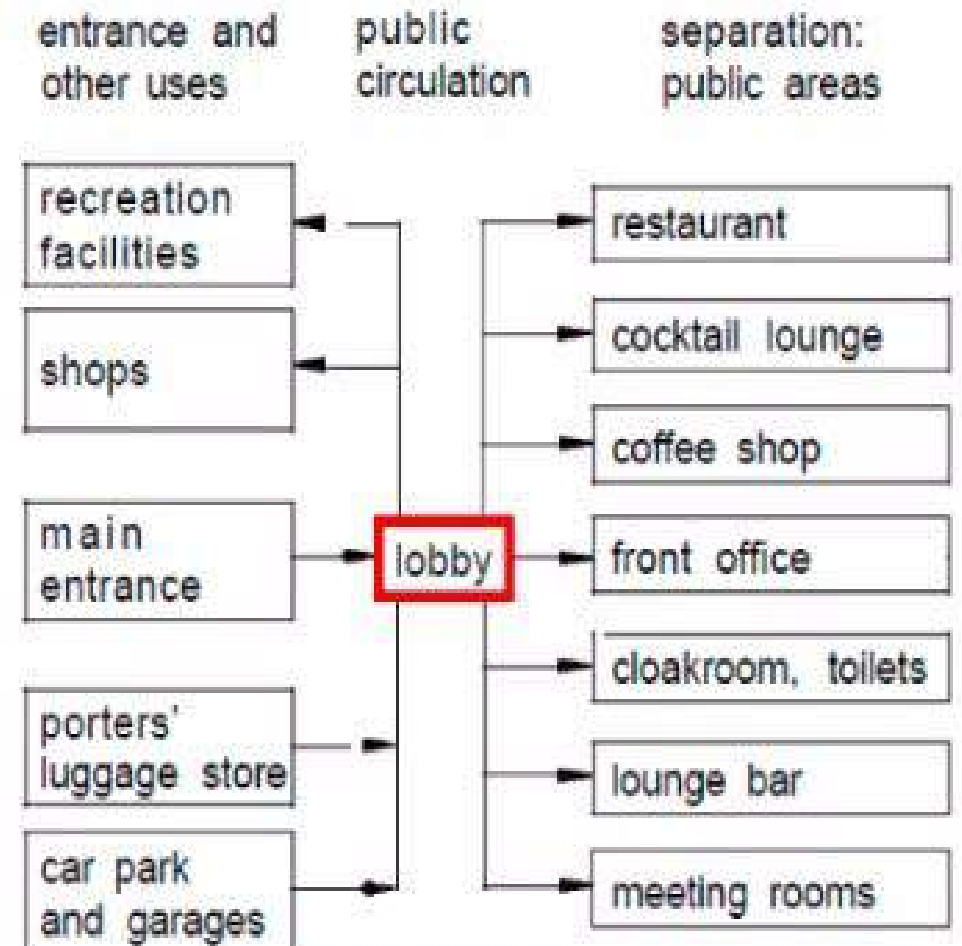

Figure 7 Circulation and relationship diagram



4.1.A) Reception hall:

- A rough planning figure is 1.1 to 1.4 m² per seat.
- It joins public area to entrance area or part of bar.
- Resort hotels may have a lounge for guest's friends.
- Furniture is normally easy chairs and low coffee tables, Atmosphere should be informal and relaxing.



reception hall relation with entrance and others activates

4.1.B) Reception desk:

- visible to the guest immediately on entrance.
- connection between direct and service and front desk service.

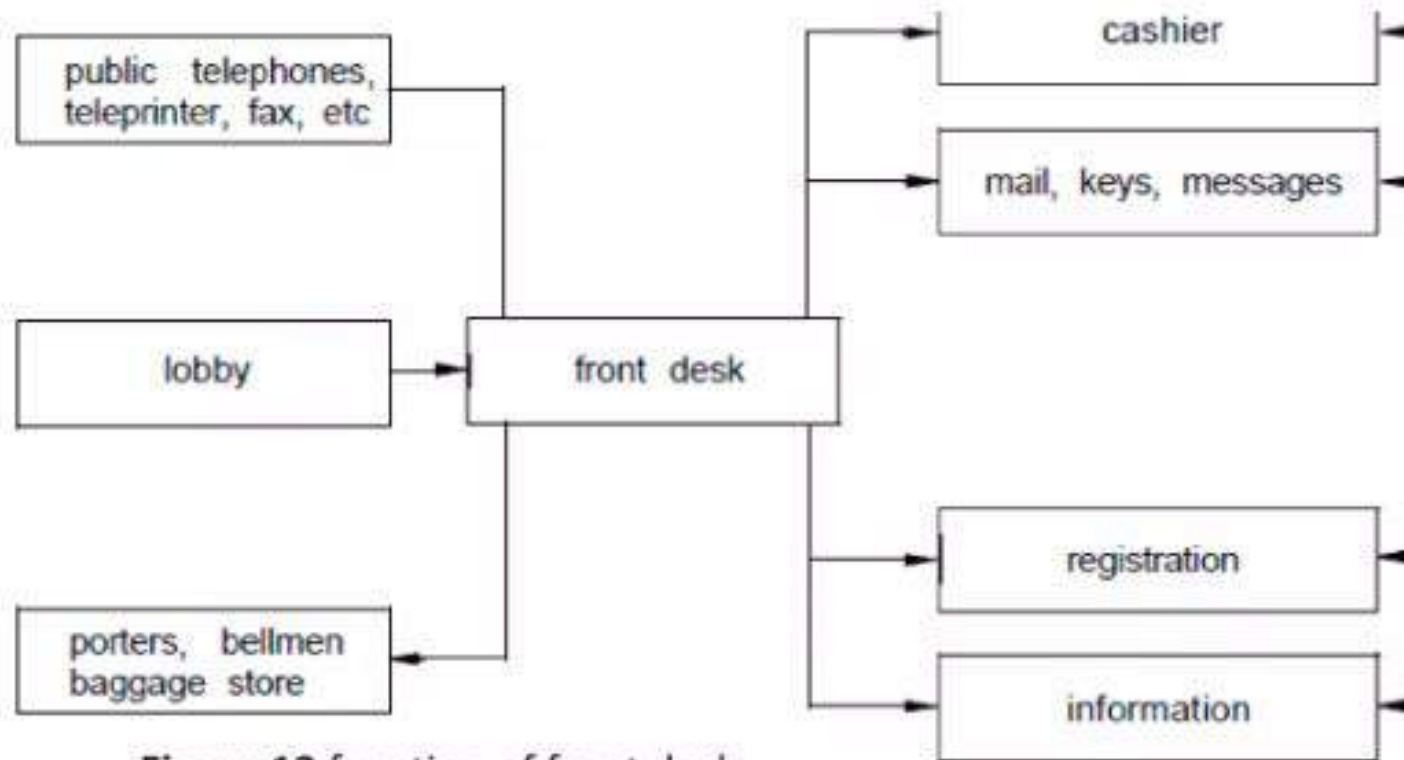

Figure 13 function of front desk

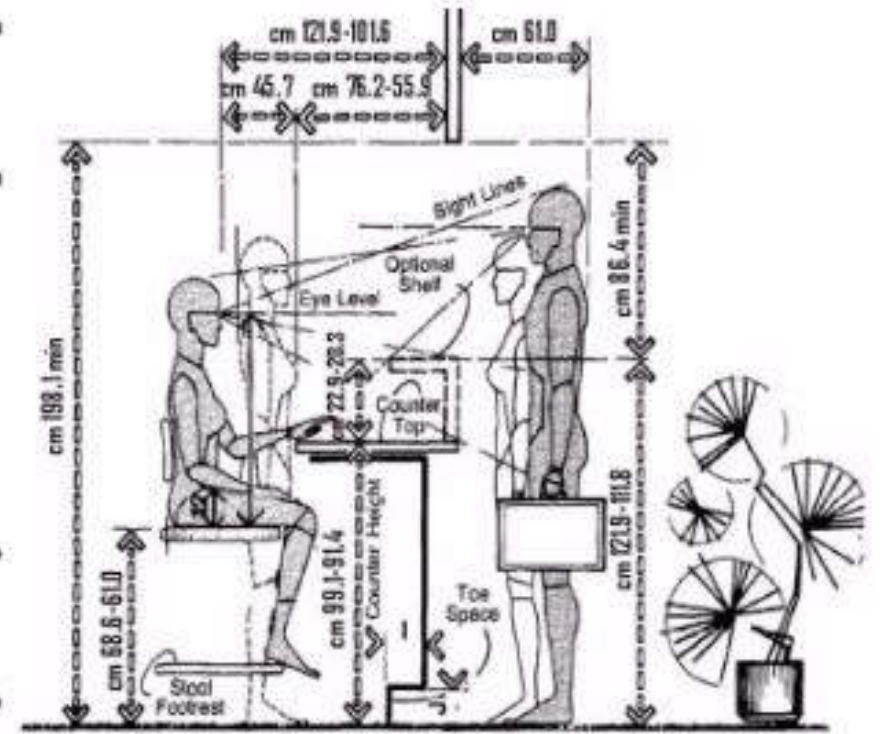
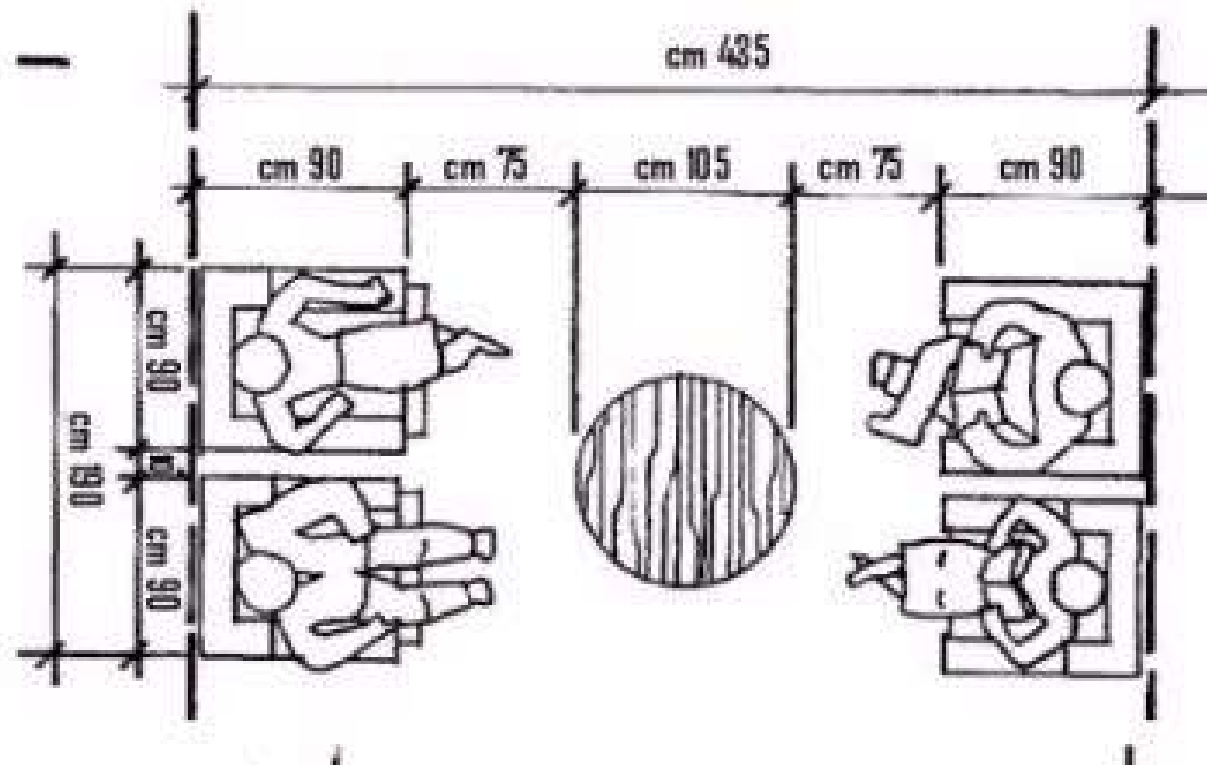
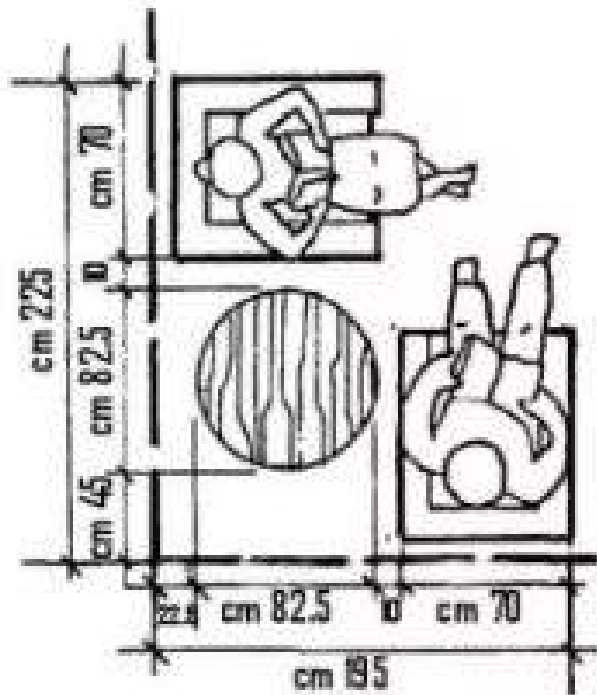

Figure 14 desk dimensions

4.1.F) Lounges:

- A rough planning figure is 1.1 to 1.4 m² per seat.
- It joins public area to entrance area or part of bar.



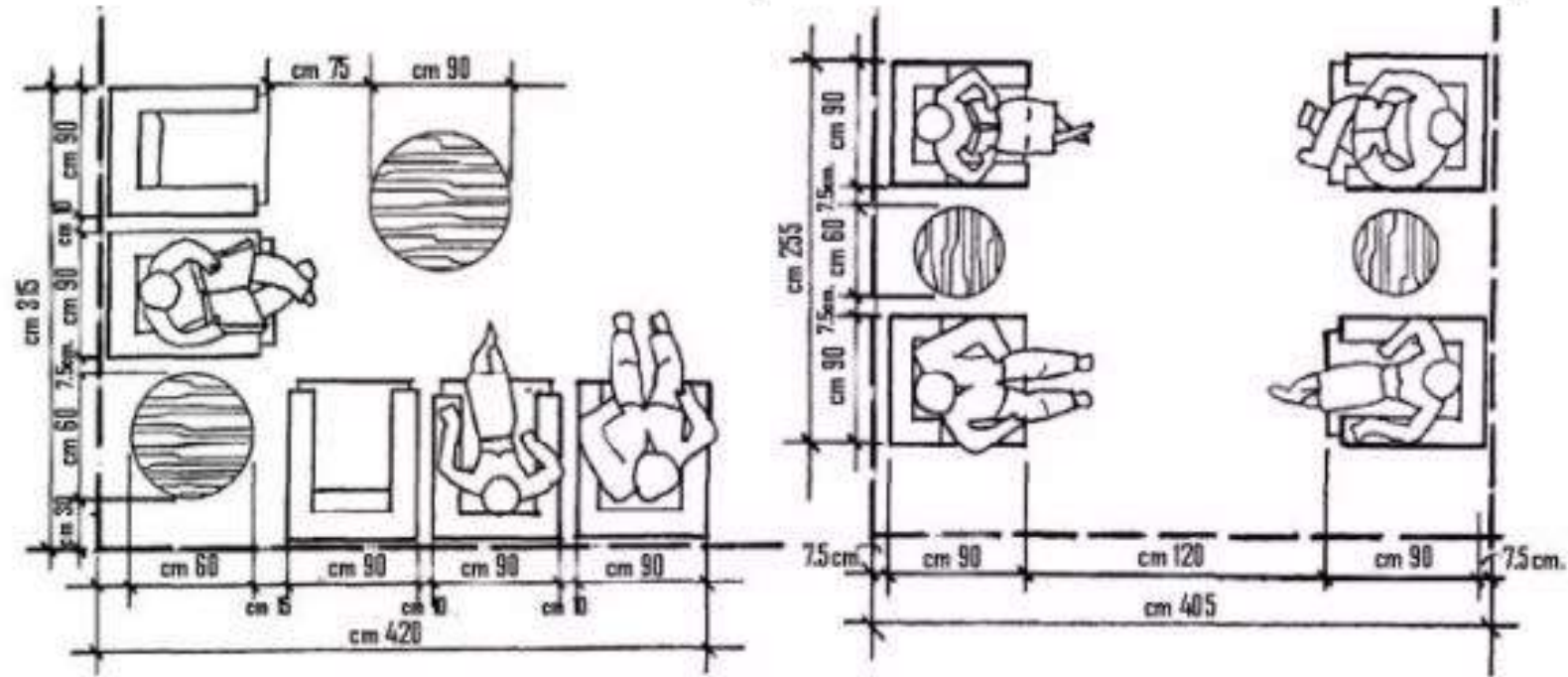

Figure 9 lunge area dimesnsions



Figure 17 Lounges area

