

*Ministry of Higher Education &
Scientific Research*

University of Salahaddin-Erbil

College of Science

Department of Mathematics

3rd Year Mathematics



Subject: Analytical Mechanics

Chapter 4:

General Motion of a Particle

Asst. Prof. Dr. Tahseen G. Abdullah

General Motion of a Particle

In Space, xyz coordinates:

$$\vec{F} = \frac{d\vec{p}}{dt} = \frac{d}{dt}(m\vec{v}) \longrightarrow \hat{i}F_x + \hat{j}F_y + \hat{k}F_z = \frac{d}{dt}[m(\hat{i}\dot{x} + \hat{j}\dot{y} + \hat{k}\dot{z})]$$

$$F_x = \frac{d}{dt}(m\dot{x}) = \frac{dp_x}{dt} \quad F_y = \frac{d}{dt}(m\dot{y}) = \frac{dp_y}{dt} \quad F_z = \frac{d}{dt}(m\dot{z}) = \frac{dp_z}{dt}$$

Rectilinear Equations

When the force is a function of time only:

$$\vec{F}(t) = \frac{d\vec{p}}{dt} \longrightarrow \int_{\vec{p}_o}^{\vec{p}} d\vec{p} = \int_0^t \vec{F}(t) dt \quad \dots \text{Impulse}$$

$$\vec{p} = \vec{p}_o + \int_0^t \vec{F}(t) dt = m\vec{v}(t) = m \frac{d\vec{r}}{dt} \longrightarrow \int_{\vec{r}_o}^{\vec{r}} d\vec{r} = \int_0^t \vec{v}(t) dt$$

$$\vec{r} = \vec{r}_o + \int_0^t \vec{v}(t) dt = \vec{r}(t) \quad \dots \text{Equation of Motion}$$

Def. of Impulse:

When a force is applied to an object, the product of the force (F) and the length of time (t) that the force is applied, is called the *impulse* of the force. Measured in Newton Seconds.

Depends on:

- ∞ The time for which the force acts
- ∞ The size of the force applied

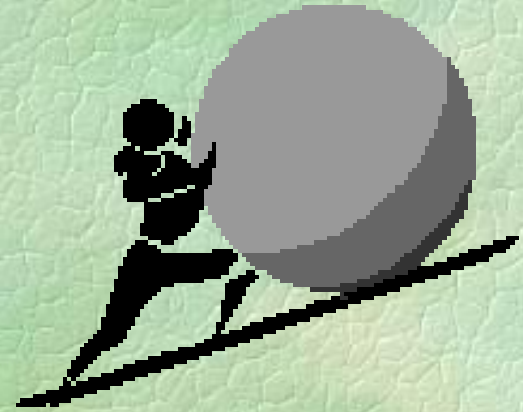

Q.: Which of the following integral represents the impulse?

- (a) $\int F(t)dt$ (b) $\int F(v)dv$ (c) $\int F(x)dx$ (d) *all of them*

Some Definitions & Equations in the General Motion

a) Angular Momentum:

$$\vec{r} \times \left(\vec{F} = \frac{d\vec{p}}{dt} \right) \longrightarrow \vec{r} \times \vec{F} = \vec{r} \times \frac{d\vec{p}}{dt}$$

We have:

$$\frac{d}{dt} (\vec{r} \times \vec{p}) = \vec{r} \times \frac{d\vec{p}}{dt} + \frac{d\vec{r}}{dt} \times \vec{p}$$

$$\begin{aligned} \vec{v} \times m\vec{v} &= m(\vec{v} \times \vec{v}) \\ &= 0 \end{aligned}$$

$$\therefore \underbrace{\vec{r} \times \vec{F}}_{\vec{\tau}} = \frac{d}{dt} \underbrace{(\vec{r} \times \vec{p})}_{\vec{L}}$$

Angular momentum of the particle about the origin

is the moment of the force about the origin of the coordinate system (Torque)

$$\vec{\tau} = \frac{d\vec{L}}{dt}$$

b) The Work Principle:

$$\left(\vec{F} = \frac{d\vec{p}}{dt}\right) \cdot \vec{v} \quad \longrightarrow \quad \vec{F} \cdot \vec{v} = \frac{d\vec{p}}{dt} \cdot \vec{v} = \frac{d(m\vec{v})}{dt} \cdot \vec{v}$$

$$\vec{F} \cdot \vec{v} = m \frac{d\vec{v}}{dt} \cdot \vec{v} = \frac{1}{2} m \frac{d}{dt} (\vec{v} \cdot \vec{v}) = \frac{d}{dt} \left(\underbrace{\frac{1}{2} m v^2}_{\text{kinetic energy}} \right) = \frac{dT}{dt}$$

Where T is the kinetic energy of the particle

$$\vec{F} \cdot d\vec{r} = dT \quad \text{or} \quad \int \vec{F} \cdot d\vec{r} = \int dT = \int dW$$

Work done on the particle by the force \vec{F} as particle moves along the path of motion is equal to the increment in kinetic energy.

c) Conservative & Non Conservative Forces :

$$\int_a^b \vec{F} \cdot d\vec{r} = \int_a^b dT = T_b - T_a$$

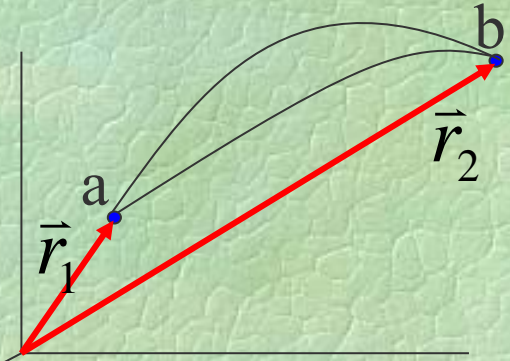

To solve the line integral we need the force and the path of motion between (a,b). When the line integral **does not depend on the path of motion** but only depends on the first and final positions the force is conservative. When the force is a function of position only the force is conservative. Mathematically, a conservative field is one in which the expression ($\vec{F} \cdot d\vec{r}$) is an exact differential.

A force for which $W_{ab} = -W_{ba}$ is called a conservative forces. This is same as saying that the net work done by a conservative force around any closed path (return back to the initial configuration) is zero. A force that is not conservative is called a nonconservative force. We cannot define potential energy associated with a nonconservative forces. ⁶

Conditions for a Force to be Conservative

A force \mathbf{F} acting on a particle is conservative if and only if it satisfies two conditions:

1. Force depends only on the particle's position \mathbf{r} (and not on the velocity \mathbf{v} , or the time t , or any other variable); that is, $\mathbf{F} = \mathbf{F}(\mathbf{r})$.
2. For any two points \mathbf{a} and \mathbf{b} , the work $W(\mathbf{a} \rightarrow \mathbf{b})$ done by \mathbf{F} is the same for all paths between \mathbf{a} and \mathbf{b} .

Two Mathematical statements for a Conservative Force:

If \vec{F} is a conservative force, we have:

$$\text{I)} \quad W_{ab.1} + W_{ba.2} = 0 \Rightarrow \int_a^b \vec{F} \cdot d\vec{r} + \int_b^a \vec{F} \cdot d\vec{r} = 0$$

$$\oint \vec{F} \cdot d\vec{r} = 0$$

...Statement 1

$$\text{II)} \quad \int_a^b \vec{F} \cdot d\vec{r}_{\text{Path1}} = - \int_b^a \vec{F} \cdot d\vec{r}_{\text{Path2}} = \int_a^b \vec{F} \cdot d\vec{r}_{\text{Path2}}$$

$$\int_a^b \vec{F} \cdot d\vec{r}_{\text{Path1}} = \int_a^b \vec{F} \cdot d\vec{r}_{\text{Path2}}$$

...Statement 2

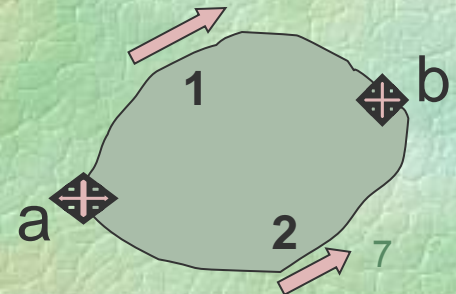
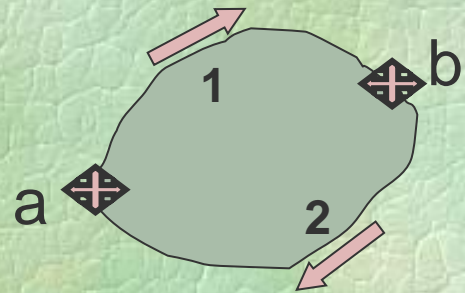

Q.: Do spring force, gravitational force, and frictional force et al. belong to conservative forces?

1. The spring force

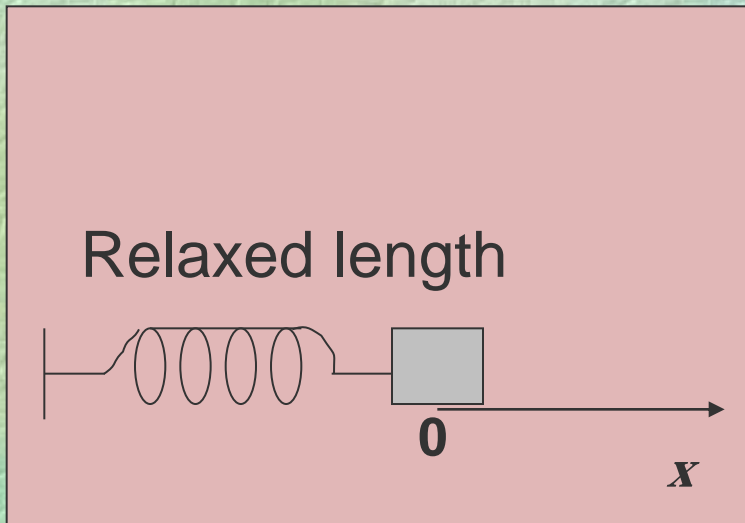

$$W_s = -\frac{1}{2}k(x_f^2 - x_i^2)$$

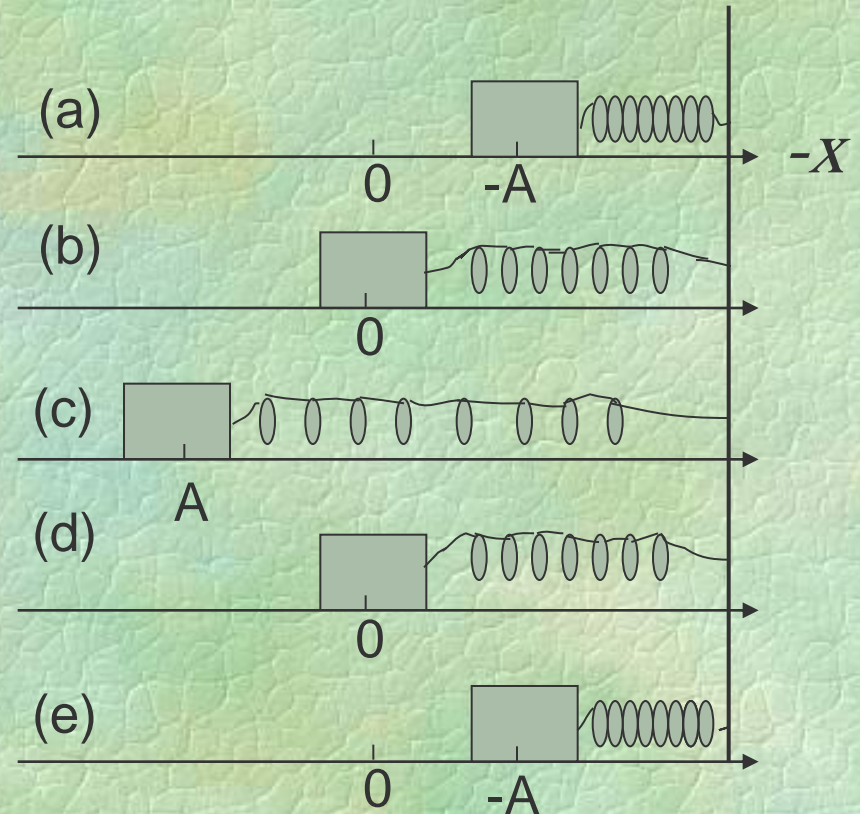

The force is conservative because the total work done by the spring force is **zero** in the process from (a) to (e) (**round trip**).

2. The force of gravity

The total work done by the gravity is **zero** during **the round trip**, So the force is conservative.

3. The frictional force

The total work done by frictional force is **not zero** in a **round trip**, So the force is nonconservative.

Two Types of Energy:

Kinetic energy \longleftrightarrow Velocity

Potential energy? \longleftrightarrow Conservative Force?

It is defined only for a certain class of forces called conservative forces.

Example : Three Line Integrals

- Evaluate the line integral for the work done by the 2-d force:

$\vec{F} = \hat{i}y + \hat{j}2x$ going from the origin O to the point $P = (1, 1)$ along each of the three paths:

a) OQ then QP $\vec{F} = \hat{i}y + \hat{j}2x$ $d\vec{r} = \hat{i}dx + \hat{j}dy$

b) OP along $x = y$ $\vec{F} \cdot d\vec{r} = ydx + 2xdy$

c) OP along a circle

□ Path a): $W_a = \int_a \vec{F} \cdot d\vec{r} = \int_0^Q \vec{F} \cdot d\vec{r} + \int_Q^P \vec{F} \cdot d\vec{r}$
 $= \int_0^1 ydx + \int_0^1 2xdy = 0 + 2 \int_0^1 dy = 2$

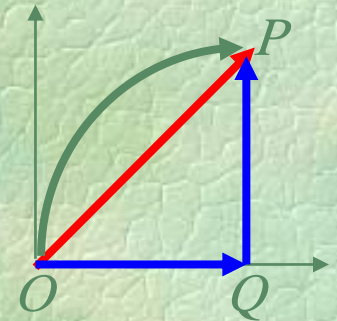

$$W_b = \int_b \vec{F} \cdot d\vec{r} = \int_0^P \vec{F} \cdot d\vec{r}$$

- Path b):

$$= \int_0^P (ydx + 2xdy) = \int_0^1 3xdx = 3 \frac{x^2}{2} \Big|_0^1 = 1.5$$

- Path c): This is a tricky one. Path c can be expressed as

$$\vec{\mathbf{r}} = (\hat{i}x + \hat{j}y) = \hat{i}(1 - \cos \theta) + \hat{j} \sin \theta$$

so

$$d\vec{\mathbf{r}} = (\hat{i}dx + \hat{j}dy) = (\hat{i} \sin \theta d\theta + \hat{j} \cos \theta d\theta)$$

This is a parametric equation, using θ as a parameter along the path, we obtain:

$$\vec{\mathbf{F}} = \hat{i}y + \hat{j}2x = \hat{i} \sin \theta + \hat{j}2(1 - \cos \theta)$$

$$\vec{\mathbf{F}} \cdot d\vec{\mathbf{r}} = \sin^2 \theta d\theta + 2((1 - \cos \theta) \cos \theta) d\theta$$

$$\begin{aligned} W_c &= \int_c \mathbf{F} \cdot d\mathbf{r} = \int_0^{\pi/2} (\sin^2 \theta + 2(1 - \cos \theta) \cos \theta) d\theta \\ &= 2 - \pi / 4 = 1.21 \end{aligned}$$

- The point here is that the line integral depends on the path, in general (but not for special kinds of forces, which we will introduce in a moment).
- In this case the force is nonconservative.

Def. of Potential Energy:

- If all of the forces on an object are conservative we can define a quantity called potential energy, denoted $V(\mathbf{r})$, a function only of position, with the property that the total mechanical energy is constant.

Such as the systems of:

Ball-Earth system & Block-spring system on frictionless table.

- To define the potential energy, we must first choose a reference point \mathbf{r}_0 , at which V is defined to be zero. (For gravity, we typically choose the reference point to be ground level.) Then $V(\mathbf{r})$, the potential energy, at any arbitrary point \mathbf{r} , is defined to be

$$V(\mathbf{r}) = -W(\mathbf{r}_0 \rightarrow \mathbf{r}) = -\int_{\mathbf{r}_0}^{\mathbf{r}} \vec{\mathbf{F}}(\mathbf{r}') \cdot d\vec{\mathbf{r}}'$$

- In words, $V(\mathbf{r})$ is minus the work done by \mathbf{F} when the particle moves from the reference point \mathbf{r}_0 to the point \mathbf{r} .

e.g. The potential energy of gravity is:

$$V = -\int_0^y (F_y) dy = -\int_0^y (-mg) dy = mgy$$

$$mgy + \frac{1}{2} m\dot{y}^2 = E = \text{const.}$$

.....Total Energy

Potential Energy Function

For conservative forces:

$\vec{F} \cdot d\vec{r} = -dV(r)$...is correct when the force is conservative

$$\vec{F} \cdot d\vec{r} = dT$$

$$E = T + V(\mathbf{r}) = \text{const.}$$

↑ Conservation Law of Energy

But, for non conservative forces:

$$\vec{F}' \cdot d\vec{r} \neq -dV(r)$$

e.g. A common example of a non conservative force is friction, then the total force is: $\vec{F} + \vec{F}'$

The work increment is then given by:

$$dT = \vec{F} \cdot d\vec{r} + \vec{F}' \cdot d\vec{r} = -dV(r) + \vec{F}' \cdot d\vec{r}$$

$$E = T + V(\mathbf{r}) \neq \text{const.}$$

$$d(T + V(r)) = \vec{F}' \cdot d\vec{r}$$

But increases or decreases as the particle moves depending on the sign of. In the case of dissipative forces the direction of \vec{F}' is opposite to that of $d\vec{r}$, hence $\vec{F}' \cdot d\vec{r}$ is negative and the E diminishes as the particle moves.

Now, for conservative forces:

$$\vec{F} \cdot d\vec{r} = F_x dx + F_y dy + F_z dz = -dV(r) = -\left(\frac{\partial V}{\partial x} dx + \frac{\partial V}{\partial y} dy + \frac{\partial V}{\partial z} dz\right)$$

Then we can write: $F_x = -\frac{\partial V}{\partial x}$, $F_y = -\frac{\partial V}{\partial y}$ & $F_z = -\frac{\partial V}{\partial z}$

$$\vec{F} = \hat{i}F_x + \hat{j}F_y + \hat{k}F_z = -\hat{i}\frac{\partial V}{\partial x} - \hat{j}\frac{\partial V}{\partial y} - \hat{k}\frac{\partial V}{\partial z}$$

$$\vec{\nabla} = \hat{i}\frac{\partial}{\partial x} + \hat{j}\frac{\partial}{\partial y} + \hat{k}\frac{\partial}{\partial z}$$

$$\vec{F} = -\left(\hat{i}\frac{\partial}{\partial x} + \hat{j}\frac{\partial}{\partial y} + \hat{k}\frac{\partial}{\partial z}\right)V \rightarrow \vec{F} = -\vec{\nabla}V$$

- Mathematically, the gradient of V or of a function is a vector that represents the maximum spatial (position) derivative of the function in direction and magnitude.
- The negative grad of P.E. function gives the direction and magnitude of the force that acts on a particle.
- The meaning of negative sign is that the particle is urged to move in the direction of decreasing (P.E) rather than in opposite direction.

Conditions for the existence of the Potential Function

$$\vec{F} = -\vec{\nabla}V$$



In general:

$$V(r) = V(x, y, z)$$

$$F_x = -\frac{\partial V}{\partial x} = F_x(x, y, z), \quad F_y = -\frac{\partial V}{\partial y} = F_y(x, y, z) \quad \& \quad F_z = \dots$$

$$\frac{\partial F_x}{\partial y} = -\frac{\partial^2 V}{\partial y \partial x}, \quad \frac{\partial F_y}{\partial x} = -\frac{\partial^2 V}{\partial x \partial y} \quad \text{but:} \quad \frac{\partial^2 V}{\partial y \partial x} = \frac{\partial^2 V}{\partial x \partial y}$$

A similar argument can be made with the pairs (F_x, F_z) and (F_y, F_z) . Thus we can write:

$$\frac{\partial F_x}{\partial y} = \frac{\partial F_y}{\partial x}$$

$$\frac{\partial F_y}{\partial z} = \frac{\partial F_z}{\partial y}$$

$$\frac{\partial F_z}{\partial x} = \frac{\partial F_x}{\partial z}$$

□ A) Necessary conditions for the existence of the potential energy function.

□ B) $\vec{\nabla} \times \vec{F} = 0$

□ C) $\vec{F} = -\vec{\nabla}V$

□ D) $E = T + V(\mathbf{r}) = \text{const.}$

□ E)

$$\vec{\nabla} \times \vec{F} = \begin{vmatrix} \hat{i} & \hat{j} & \hat{k} \\ \frac{\partial}{\partial x} & \frac{\partial}{\partial y} & \frac{\partial}{\partial z} \\ F_x & F_y & F_z \end{vmatrix}$$

$$= \hat{i} \left(\frac{\partial F_z}{\partial y} - \frac{\partial F_y}{\partial z} \right) - \hat{j} \left(\frac{\partial F_z}{\partial x} - \frac{\partial F_x}{\partial z} \right) + \hat{k} \left(\frac{\partial F_y}{\partial x} - \frac{\partial F_x}{\partial y} \right)$$

If $\vec{\nabla} \times \vec{F} = 0 \rightarrow$ The Force is Conservative.
If not it is Non-conservative.

Ex.: Show that forces of the separable type are conservative.

Forces of the separable type are:

$$F_x = F_x(x) , \quad F_y = F_y(y) \quad \& \quad F_z = F_z(z) ,$$

$\vec{\nabla} \times \vec{F} = 0 \rightarrow$ The Force is Conservative

Ex.: Is the force field $\vec{F} = \hat{i}xy + \hat{j}xz + \hat{k}yz$ conservative?

$$\vec{\nabla} \times \vec{F} = \begin{vmatrix} \hat{i} & \hat{j} & \hat{k} \\ \frac{\partial}{\partial x} & \frac{\partial}{\partial y} & \frac{\partial}{\partial z} \\ xy & xz & yz \end{vmatrix} = \hat{i}(z-x) - \hat{j}(0) + \hat{k}(z-x) \neq 0$$

The final expression is not zero for all values of the coordinates, hence the field is not conservative.

Ex.: For what values of the constants a, b and c is the force $\vec{F} = \hat{i}(ax + by^2) + \hat{j}cxy$ conservative?

$$\vec{\nabla} \times \vec{F} = \begin{vmatrix} \hat{i} & \hat{j} & \hat{k} \\ \frac{\partial}{\partial x} & \frac{\partial}{\partial y} & \frac{\partial}{\partial z} \\ (ax + by^2) & cxy & 0 \end{vmatrix} = \hat{k}(c - 2b)y$$

This shows that the force is conservative, provided $c=2b$.
The value of a is immaterial.

Ex.: Given the potential energy function:

$$V(r) = \alpha x^2 + \beta xy + \gamma z + c$$

in which α, β, γ and c are constants.

Find the force function.

Applying the del operator, we have:

$$\begin{aligned}\vec{F} &= -\vec{\nabla}V = -\left(\hat{i} \frac{\partial V}{\partial x} + \hat{j} \frac{\partial V}{\partial y} + \hat{k} \frac{\partial V}{\partial z}\right) \\ &= -\hat{i}(2\alpha x + \beta y) - \hat{j}(\beta x) - \hat{k}\gamma\end{aligned}$$

Ex.: Suppose a particle of mass m is moving in the above force field, and at time $t=0$ the particle passes through the origin with speed v_0 . What will the speed of the particle be if and when it passes through the point $\vec{r} = \hat{i} + 2\hat{j} + \hat{k}$? (H.W.)

Projectile Motion & Air Resistance

When a projectile moves through the air (or other medium—such as gas or liquid), it experiences a drag force, which depends on velocity and acts in the direction opposite the motion (i.e. it always acts to slow the projectile).

While the effect of air resistance may be very small in some cases, it can be rather important and complicated.

e.g. motion of a golf ball.

- **Basic Facts and Characteristics**
 - Not a fundamental force...
 - Friction force resulting from different atomic phenomena
 - Depends on the velocity relative to the embedding fluid.
 - Direction of the force opposite to the velocity (typically).
 - **Air resistance is known under different names:** Drag, Retardation Force, and Resistive Force

Air Resistance - Drag Force

∞ Consider retardation force strictly anti-parallel to the velocity.

$$\vec{f} = -f(v)\hat{v}$$

∞ Where $\hat{v} = \hat{t} = \frac{\vec{v}}{v}$

• $f(v)$ is the magnitude of the force.

∞ Measurements reveal $f(v)$ is complicated - especially near the speed of sound...

∞ At low speed, one can write as a good approximation:

$$f(v) = bv + cv^2 = f_{lin} + f_{quad}$$

$$\text{where } f_{lin} = bv \quad \& \quad f_{quad} = cv^2$$

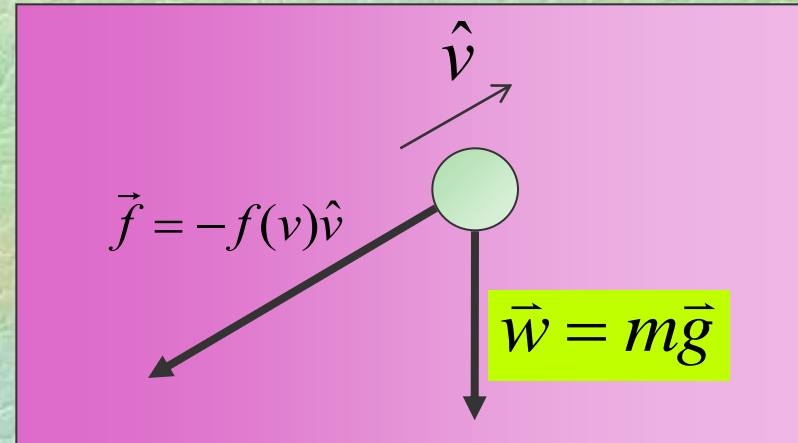

The physical reasons for these two different terms are as follows: The linear term arises due to the viscous drag of the medium, and is proportional to the viscosity of the medium and the linear size D of the projectile.

The quadratic term arises from the projectile's having to accelerate the mass of air with which it is continually colliding, and is proportional to the density of the medium and the cross-sectional area D^2 of the projectile. That is

- The linear term drag is proportional to the viscosity, η
- The quadratic term is related to the density of the fluid, ρ .

- We have: $\frac{f_{quad}}{f_{lin}} : R \equiv \frac{Dv\rho}{\eta}$

Reynolds Number

where $f_{lin} = bv$ & $f_{quad} = cv^2$

For a **spherical projectile** (e.g. canon ball, baseball, drop of rain):

$b = \beta D$ where D is the diameter of the sphere.

$c = \gamma D^2$ β and γ depend on the nature of the medium

$$\beta = 1.6 \times 10^{-4} \text{ Ns/m}^2$$

$$\gamma = 0.25 \text{ Ns}^2/\text{m}^4$$

Using values of these parameters the ratio of quadratic force to the linear force is given by:

$$\frac{f_{quad}}{f_{lin}} = \frac{cv^2}{bv} = \frac{\gamma D}{\beta} v = \left(1.6 \times 10^3 \frac{s}{m^2}\right) Dv \quad \left\{ \begin{array}{l} = 1: \text{ linear case} \\ ? 1: \text{ quadratic case} \end{array} \right.$$

• Example: Baseball and Liquid Drops

- A baseball has a diameter of $D = 7$ cm, and travel at speed of order $v=5$ m/s.

$$\frac{f_{quad}}{f_{lin}} \approx 600 \quad \rightarrow \quad \vec{f} = -cv^2 \hat{v}$$

- A drop of rain has $D = 1$ mm and $v=0.6$ m/s

$$\frac{f_{quad}}{f_{lin}} \approx 1 \quad \rightarrow \quad \text{Neither term can be neglected.}$$

- Millikan Oil Drop Experiments, $D=1.5$ mm and $v=5 \times 10^{-5}$ m/s.

$$\frac{f_{quad}}{f_{lin}} \approx 10^{-7} \quad \rightarrow \quad \vec{f} = -b\vec{v}$$

Physical Differential Equations of the Projectile Motion

I. Projectile Motion Without Air Resistance

- For a projectile without air resistance, Newton's 2nd Law (equation of motion) becomes:

$$m\vec{a} = m\ddot{\vec{r}} = \sum \text{Forces}$$

- Thus the first-order differential equation is:

$$m\vec{a} = m\vec{g} \quad \longrightarrow \quad m(\hat{i}\ddot{x} + \hat{j}\ddot{y} + \hat{k}\ddot{z}) = m(\hat{k}g)$$

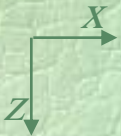

- This vector equation represents (in two dimensions) two separate equations for the x and y components

$$m\ddot{x} = ma_x = 0 \quad \& \quad m\ddot{y} = ma_y = 0$$

$$m\ddot{z} = mg \rightarrow ma_z = mg$$

$$y = v_{oy}t = \dot{y}_o t$$

- Or:

$$a_x = 0 \quad \longrightarrow \quad v_x = \text{const.} = v_{ox} \quad \longrightarrow \quad x = v_{ox}t = \dot{x}_o t$$

$$a_z = g = \text{const.} \quad \longrightarrow \quad v_z = v_{oz} + gt \quad \longrightarrow \quad z = v_{oz}t + \frac{1}{2}gt^2$$

$$\therefore \vec{r} = \hat{i}x + \hat{j}y + \hat{k}z = \vec{v}_o t + \frac{1}{2}gt^2 \hat{k}$$

Note:

$$a_x = \ddot{x} = \dot{v}_x \quad \& \quad v_x = \dot{x}$$

II. Projectile Motion with Linear Air Resistance

- For a projectile with linear drag, the projectile experiences both gravity and the drag force, the latter directed in the opposite direction of its motion. Newton's 2nd Law (equation of motion) becomes

$$m\ddot{\mathbf{r}} = \sum \text{Forces} \rightarrow m\ddot{\mathbf{r}} = m\vec{g} - b\vec{v}$$

- Thus the first-order differential equation for \mathbf{v} is:

$$m(\hat{i}\dot{v}_x + \hat{j}\dot{v}_y + \hat{k}\dot{v}_z) = m(\hat{j}g) - b(\hat{i}v_x + \hat{j}v_y + \hat{k}v_z)$$

$$m(\hat{i}\dot{v}_x + \hat{j}\dot{v}_y) = m(\hat{j}g) - b(\hat{i}v_x + \hat{j}v_y)$$

- This vector equation represents (in two dimensions) two separate equations for the x and y components

$$m\dot{v}_x = -bv_x$$

$$m\dot{v}_y = mg - bv_y \Rightarrow v_y = ? \Rightarrow y = ?$$

- Notice that the two equations do not depend on one another.
- The second equation is the same as the equation of vertical motion with linear drag (See Chapter 3).

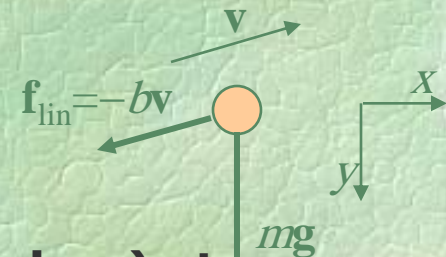

$$m\dot{v}_x = -bv_x$$

$$\frac{dv_x}{dt} = -\frac{b}{m}v_x \quad \Rightarrow \quad \frac{dv_x}{v_x} = -\frac{b}{m}dt \quad \ln v_x = -\frac{b}{m}t + c$$

where c is an arbitrary constant of integration. Taking the inverse ln of both sides, and writing $b/m=k$, we have:

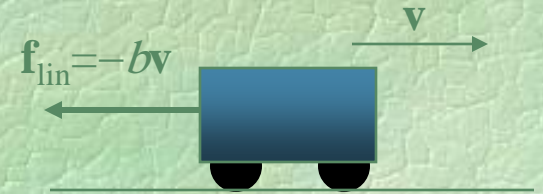

$$v_x = Ae^{-kt} = v_{x0}e^{-kt} = \frac{dx}{dt}$$

where the arbitrary constant of integration has morphed into $v = v_{x0}$ at $t=0$.

□ The final solution for the position is $x(t) = x_{\infty}(1 - e^{-t/\tau})$

□ where we have introduced the parameter $x_{\infty} = v_{x0}\tau$, the value of x as $t \rightarrow \infty$

$$\tau = 1/k = m/b \quad \text{[for linear drag]}$$

□ The final solutions for $v(t)$ and $x(t)$ are: $v_x(t) = v_{x0} e^{-t/\tau}$ $x(t) = x_\infty (1 - e^{-t/\tau})$

$$\tau = m/b \quad \text{[for linear drag]} \quad x_\infty = v_{x0} \tau$$

□ Graphs of these functions are:

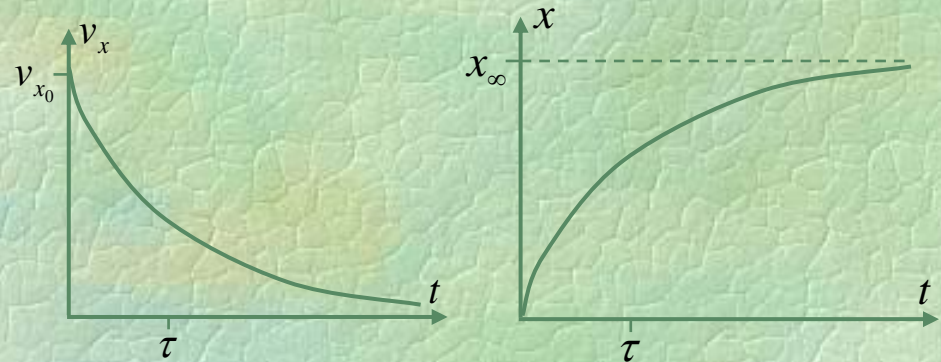

□ To get a trajectory including BOTH horizontal and vertical motion, we should consider y position *upward*. Thus, our two equations are:

$$x(t) = v_{x0} \tau (1 - e^{-t/\tau}) \quad y(t) = (v_{y0} + v_{\text{ter}}) \tau (1 - e^{-t/\tau}) - v_{\text{ter}} t$$

□ We can combine these into a single equation by solving the first for t

$$t = -\tau \ln \left(1 - \frac{x}{v_{x0} \tau} \right)$$

and substituting into the second:

$$y = \frac{v_{y0} + v_{\text{ter}}}{v_{x0}} x + v_{\text{ter}} \tau \ln \left(1 - \frac{x}{v_{x0} \tau} \right)$$

□ This is rather too complicated to understand easily, but here is a plot of the trajectory compared with one without air resistance.

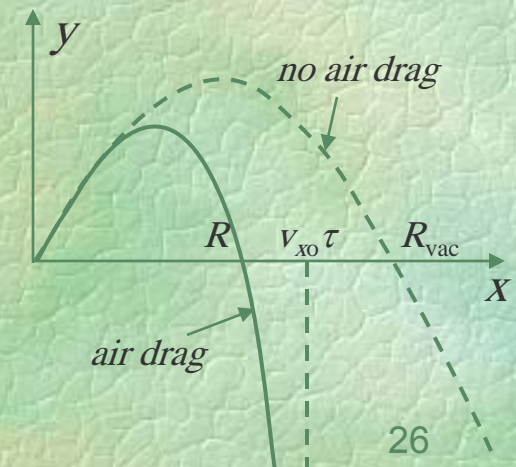

III. Projectile Motion with Quadratic Air Resistance

- For a projectile with quadratic drag, the projectile experiences both gravity and the drag force, the latter directed in the opposite direction of its motion. Newton's 2nd Law (equation of motion) becomes

$$m\ddot{\mathbf{r}} = \sum \text{Forces} \quad \rightarrow \quad m\ddot{\mathbf{r}} = m\bar{\mathbf{g}} - cv^2 \hat{\mathbf{t}}$$

$$m\ddot{\mathbf{r}} = m\bar{\mathbf{g}} - cv\bar{\mathbf{v}}$$

- or $m(\hat{i}\dot{v}_x + \hat{j}\dot{v}_y + \hat{k}\dot{v}_z) = m(\hat{k}g) - cv(\hat{i}v_x + \hat{j}v_y + \hat{k}v_z)$

- This vector equation represents three separate equations for the x , y and z components:

$$m\dot{v}_x = -cvv_x \quad \& \quad m\dot{v}_y = -cvv_y \quad \text{where } v = \sqrt{\dot{x}^2 + \dot{y}^2 + \dot{z}^2}$$

$$m\dot{v}_z = mg - cvv_z \quad = \sqrt{v_x^2 + v_y^2 + v_z^2}$$

- Notice that the three equations are not of the separable type.
- From the first two equations we obtain:

$$v_x = v_{x0} e^{-\gamma s} \quad \& \quad v_y = v_{y0} e^{-\gamma s} \quad \text{where } \gamma = c/m$$

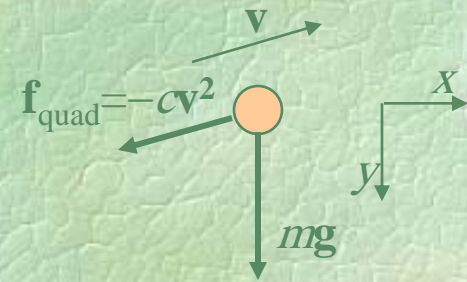

Motion of Charged Particle

I) Motion of Charged Particle in Electric Field

In general, the differential equation of motion for charged particle is:

$$\vec{F} = m\vec{a} = m \frac{d\vec{v}}{dt} = q(\vec{E} + \vec{v} \times \vec{B})$$

In Electric Field: $\vec{F} = m\vec{a} = q\vec{E} \text{ \& \ } \vec{B} = 0$

For Static Uniform Electric Field:

$$\vec{E} = \hat{k}E \quad \rightarrow \quad E_x = E_y = 0 \text{ \& \ } E_z = \text{const.} = E$$

Then:

$$m(\hat{i}\ddot{x} + \hat{j}\ddot{y} + \hat{k}\ddot{z}) = qE\hat{k}$$

where

$$\ddot{x} = a_x, \quad \ddot{y} = a_y \text{ \& \ } \ddot{z} = a_z$$

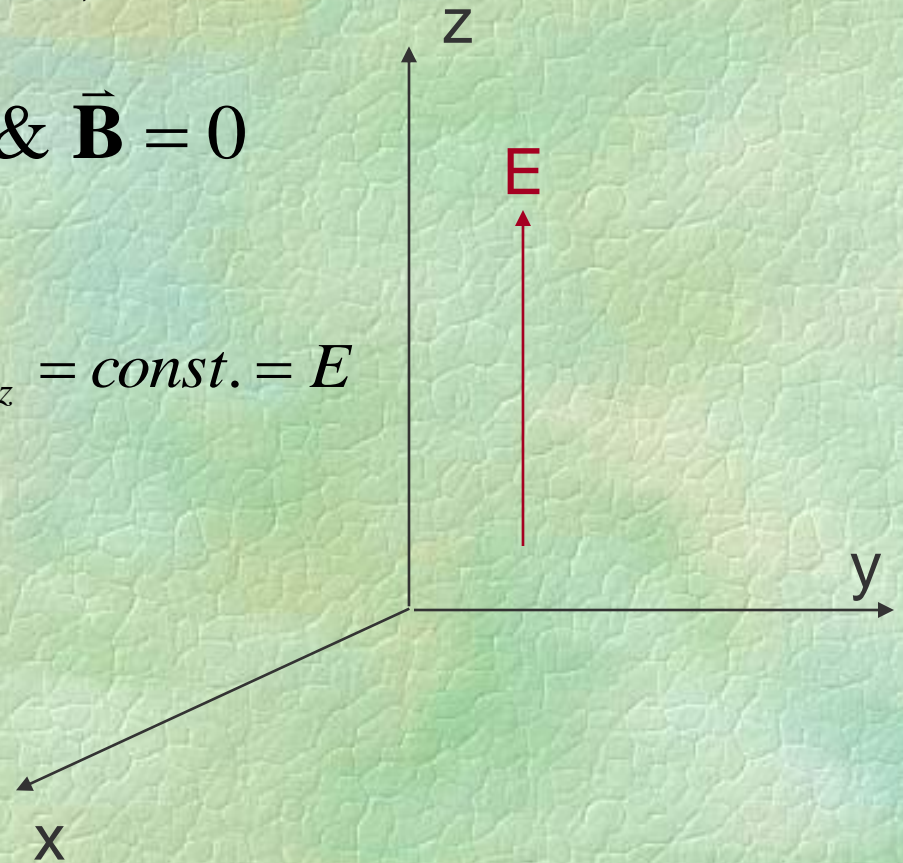

⇒ Consider particle at rest, at origin, at $t=0$

$$\ddot{x} = 0$$

$$\ddot{y} = 0$$

$$\ddot{z} = \frac{qE}{m} = \text{const.}$$



$$\dot{x} = 0$$

$$\dot{y} = 0$$

$$\dot{z} = \frac{qE}{m}t$$



$$x = 0$$

$$y = 0$$

$$z = \frac{qE}{2m}t^2$$

...The path
is parabola

When the electric field is due to the static charges:

$$\vec{\nabla} \times \vec{E} = 0$$

$$\vec{F} = q\vec{E} \Rightarrow \vec{\nabla} \times \vec{F} = 0$$

This means that the field is conservative and there exists a potential function Φ such that:

$$\vec{E} = -\vec{\nabla}\Phi$$

The potential energy of a particle of charge q in such a field is then $q\Phi$ and the total energy:

$$E = \frac{1}{2}mv^2 + q\Phi = \text{const.}$$

Energy Equation for Motion of Charged Particle in a Uniform Static Electric Field

II) Motion of Charged Particle in Magnetic Field

∞ The force on a charge moving in a magnetic field is:

$$\vec{F} = m\vec{a} = m\dot{\vec{v}} = q(\vec{v} \times \vec{B})$$

where q is the charge and \vec{B} is the magnetic field strength. The equation of motion is a first-order differential equation in \vec{v} .

∞ In this type of problem, we are often free to choose our coordinate system so that the magnetic field is along one axis, say the z -axis:

$$\vec{B} = \hat{k}B \quad \dots \text{Static magnetic field}$$

and the velocity can in general have any direction $\vec{v} = \hat{i}\dot{x} + \hat{j}\dot{y} + \hat{k}\dot{z}$

Hence,
$$\vec{v} \times \vec{B} = \hat{i}\dot{y}B - \hat{j}\dot{x}B$$

Thus, the equation of motion becomes:

$$m(\hat{i}\ddot{x} + \hat{j}\ddot{y} + \hat{k}\ddot{z}) = \hat{i}\dot{y}qB - \hat{j}\dot{x}qB$$

↻ The three components of the equation of motion are:

$$m\ddot{x} = qB\dot{y}$$

$$m\ddot{y} = -qB\dot{x}$$

$$m\ddot{z} = 0$$

$$\ddot{x} = \omega\dot{y}$$

$$\ddot{y} = -\omega\dot{x}$$

$$\ddot{z} = 0$$

$$\dot{x} = \omega y + c_1$$

$$\dot{y} = -\omega x + c_2$$

$$\dot{z} = \text{const.}$$

where $\omega = qB/m$ is cyclotron frequency

- the last equation simply says that the component of velocity along \mathbf{B} , is constant. Let's now focus on the other two components, and ignore the motion along \mathbf{B} . We can then consider the velocity as a two-dimensional vector (v_x, v_y) = transverse velocity.
 - Solve 2nd eq.,
 - Sub into 1st eq
 - *Vice versa*

- From 3rd equation: $\frac{d\dot{z}}{dt} = 0 \Rightarrow \dot{z} = \text{const.} = \dot{z}_o = \frac{dz}{dt} \Rightarrow z = \dot{z}_o t$

- From other equations:

$$\ddot{x} = \omega \dot{y} = \omega(-\omega x + c_2) = -\omega^2 x + \omega^2 a \quad \text{where } c_2 = \omega a$$

or $\ddot{x} + \omega^2 (x - a) = 0$

The solution is the same as the solution of SHO equation:

$$x = a + A \cos(\omega t + \alpha)$$

From this equation we obtain

where $b = -c_1 / \omega$

$$\dot{x} = -A\omega \sin(\omega t + \alpha) \quad \& \quad y = b - A \sin(\omega t + \alpha)$$

The form of the path of motion is: $(x - a)^2 + (y - b)^2 = A^2$

Thus the projection of the path of motion on the xy plane is a circle of radius A centered at the point (a, b) . The path is spiral (helical) and A is directly proportional to the speed.

III) Motion of Charged Particle in Electromagnetic Field

In this case, the differential equation of motion for charged particle is:

$$\vec{F} = m\vec{a} = m \frac{d\vec{v}}{dt} = q(\vec{E} + \vec{v} \times \vec{B})$$

For Static Uniform Electric and Magnetic Fields:

$$\vec{E} = \hat{j}E \quad \& \quad \vec{B} = \hat{k}B$$

Notes:

- Charged particles accelerated by electric field
- Circular motion in plane normal to magnetic field

Q.1: Find the resulting motion of charged particle (H.W)

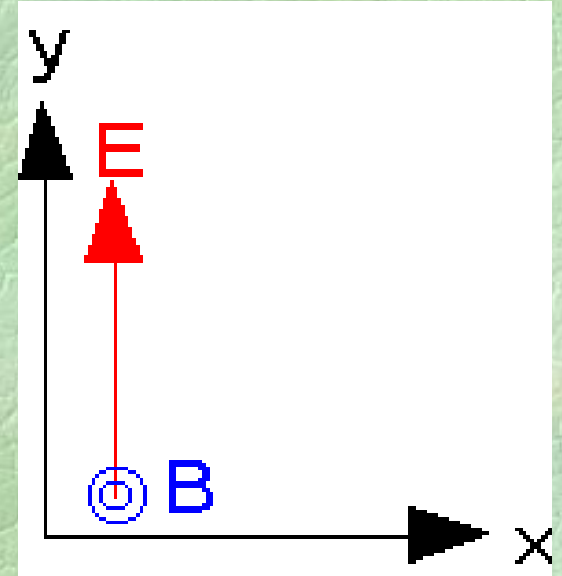

Constrained Motion of a Particle

Definitions:

Unconstrained motion: the particle is free of mechanical guides.

Ex. Airplane, rocket

Constrained motion: the path of particle is partially or totally determined by restraining guides.

Ex. A train moving along track, a particle sliding on sphere.

For smooth constraint, the force of constraint is normal to the direction of motion.

The total force acting on the particle moving under constraint:

$$m\vec{a} = \vec{F} + \vec{R} \quad \text{...Differential Equation for Constrained Motion}$$

\vec{F} \rightarrow is the external force

\vec{R} \rightarrow is the force of constraint (the reaction of the constraining upon the particle)

$$\left[m \frac{d\vec{v}}{dt} = \vec{F} + \vec{R} \right] \cdot \vec{v} \rightarrow m \frac{d\vec{v}}{dt} \cdot \vec{v} = \vec{F} \cdot \vec{v} + \vec{R} \cdot \vec{v}$$

Now, for Smooth Constraint: $\vec{R} \perp \vec{v} \Rightarrow \vec{R} \cdot \vec{v} = 0$

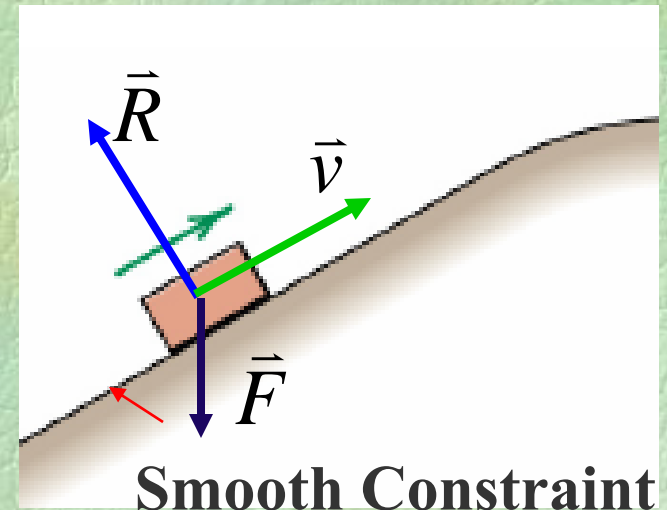

$$\vec{F} \cdot \vec{v} = \frac{m}{2} \frac{d}{dt} (\vec{v} \cdot \vec{v}) = \frac{d}{dt} \left(\frac{1}{2} m v^2 \right) = \frac{dT}{dt}$$



$$\vec{F} \cdot d\vec{r} = dT$$

If the force is conservative, the potential energy function exist and:

$$\vec{F} \cdot d\vec{r} = -dV$$

$$T + V = \frac{1}{2} m v^2 + V(\vec{r}) = E = \text{const.}$$



Smooth Constraint & the force is conservative

Example: A particle is placed on top of a smooth sphere of radius (a). If the particle is slightly disturbed, at what point will it leave the sphere?

The total force acting on the particle are:

$$m \frac{d\vec{v}}{dt} = m\vec{g} + \vec{R}$$

The radial components of the equation is:

$$m \frac{v^2}{a} = mg \cos \theta - R$$

From the energy equation:

$$\frac{1}{2}mv^2 + V(\vec{r}) = E = \text{const.}$$

At point A: $E_A = mga$

At point B: $E_B = \frac{1}{2}mv^2 + mgz$

$$E_A = E_B \rightarrow v^2 = 2g(a - z)$$

$$R = mg \frac{z}{a} - \frac{m}{a} 2g(a - z) = \frac{mg}{a} (3z - 2a)$$

Thus R vanishes when: $z = 2a/3$

At which point the particle will leave the sphere

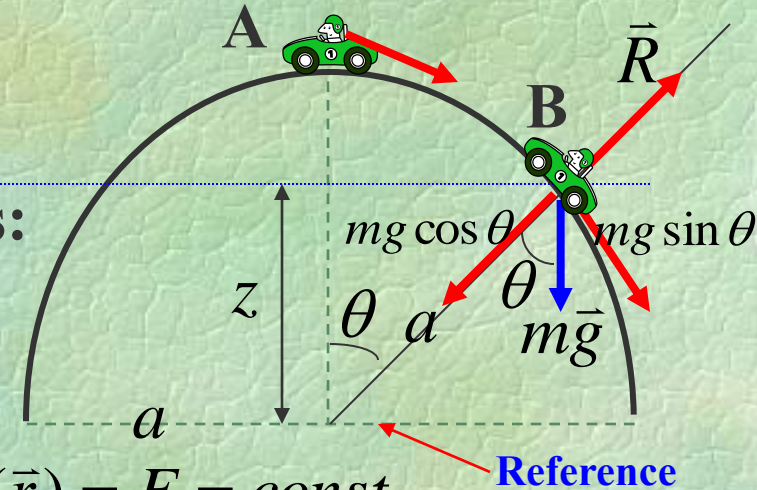

Differential and Energy equations for Motion on a Curve

- Curvilinear Motion.
- Movement along a curved line.
- Most jumps are along a curved line.

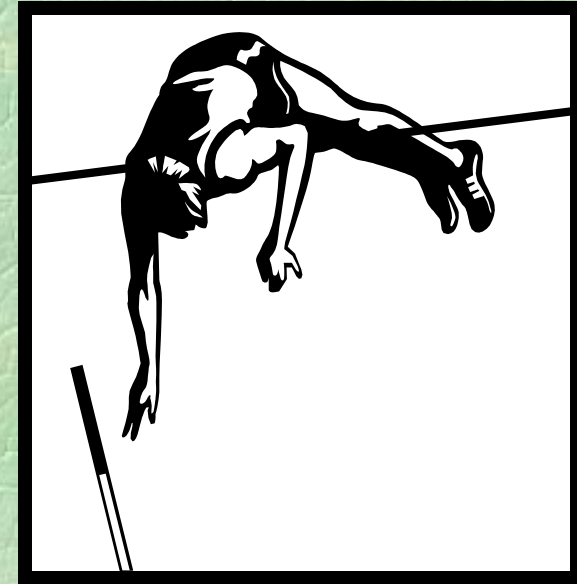

In general the Energy Equation is:

$$\frac{1}{2}mv^2 + V(x, y, z) = E = \text{const.} \quad v = \frac{ds}{dt} = \dot{s}$$

We can write the equations of the curve in parametric form:

$$x=x(s), y=y(s) \text{ \& } z=z(s)$$

s is the distance measured along the curve from the origin

$$V(x, y, z) = V(x(s), y(s), z(s)) = V(s)$$

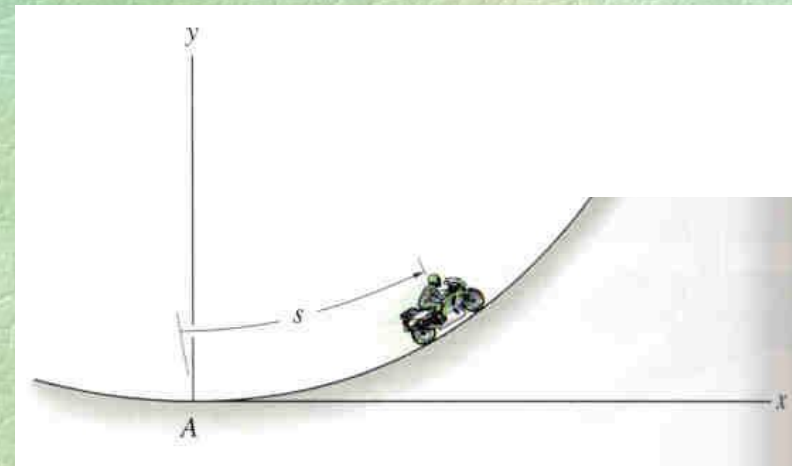

$$\frac{1}{2} m \dot{s}^2 + V(s) = E = \text{const.}$$

...Energy equation for motion of the particle on the curve

Differentiating the energy equation with respect to t :

$$\frac{d}{dt} \left[\frac{1}{2} m \dot{s}^2 + V(s) = E \right] \longrightarrow m \ddot{s} + \frac{dV(s)}{ds} \frac{ds}{dt} = 0$$

$$F_s = m \ddot{s} = - \frac{dV(s)}{ds}$$

....Differential equation for motion of the particle on the curve

is the component of the external force in the direction of s

Example: The Simple Pendulum

A simple pendulum consists of a mass m (of negligible size) suspended by a string or rod of length L (and negligible mass).

The angle it makes with the vertical varies with time as a sine or cosine.

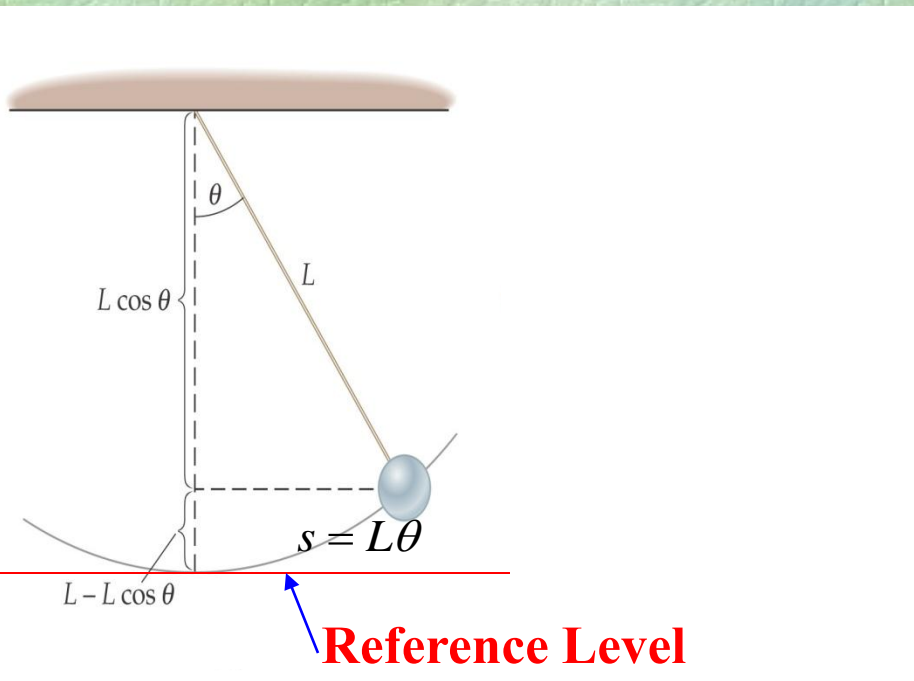

$$V(s) = mg(L - L \cos \theta)$$

$$F_s = m\ddot{s} = -\frac{dV(s)}{ds}$$

$$m\ddot{s} = -mgL \sin \frac{s}{L} \left(\frac{1}{L} \right)$$

For small angles:

$$\ddot{s} + \frac{g}{L} s = 0 \text{ or } \ddot{\theta} + \frac{g}{L} \theta = 0$$

The solution:

$$s = A \cos(\omega_0 t + \varphi) \text{ or } \theta = A \cos(\omega_0 t + \varphi)$$

The Isochronous Problem

The differential equation of motion

If this equation represents SHM we must have:

Now, we can find x & y in terms of θ , as follows:

$$\frac{dx}{d\theta} = \frac{dx}{ds} \frac{ds}{d\theta} = \cos \theta (c \cos \theta) = c \cos^2 \theta$$

$$\int_0^x dx = \int_0^\theta c \cos^2 \theta d\theta \quad \& \quad \int_0^y dy = \int_0^\theta c \sin \theta \cos \theta d\theta$$

$$x = \frac{c}{4} (2\theta + \sin 2\theta) \quad \& \quad y = \frac{c}{4} (1 - \cos 2\theta)$$

Parametric Equations of a Cycloid

$$F_s = m\ddot{s} = -mg \sin \theta$$

$$m\ddot{s} = -ks \text{ or } s = c \sin \theta$$

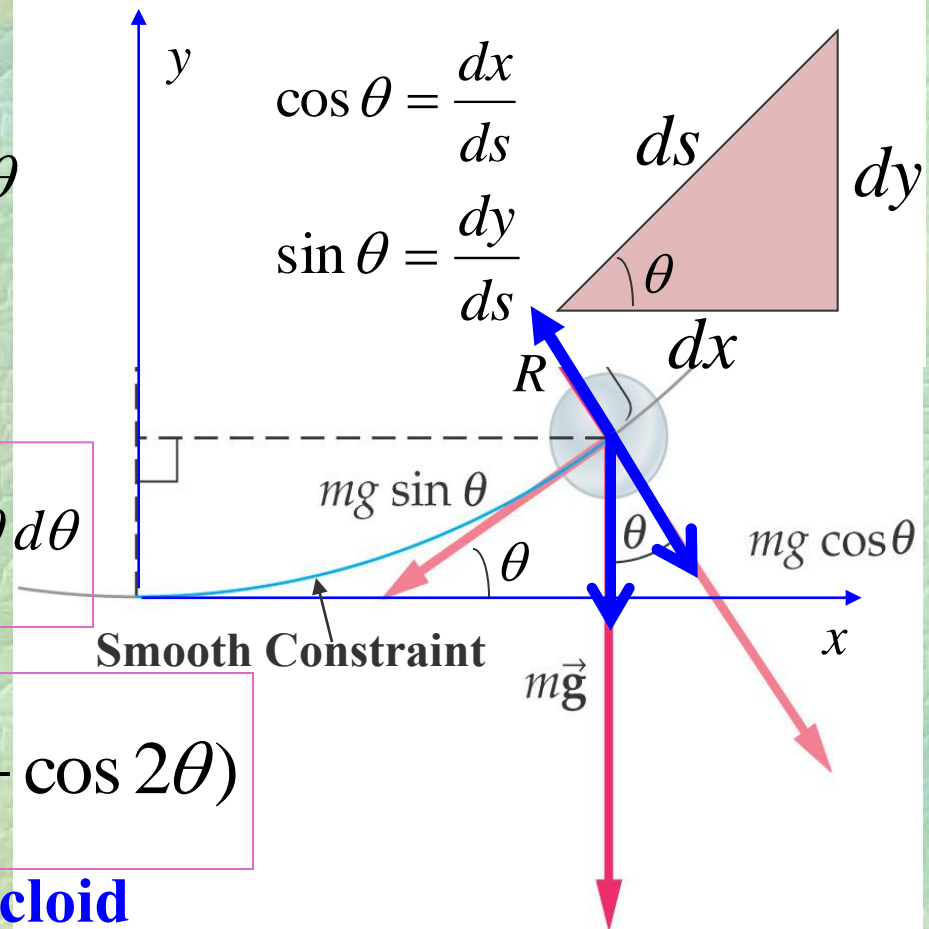

Problems:

P.1: Find the force for each of the following potential energy function:

$$(a) V = cxyz + c$$

$$(b) V = \alpha x^2 + \beta y^2 + \gamma z^2 + c$$

$$(c) V = ce^{-(\alpha x + \beta y + \gamma z)}$$

$$\text{Sol. (a)} \quad \vec{F} = -\vec{\nabla}V = -\left(\hat{i} \frac{\partial V}{\partial x} + \hat{j} \frac{\partial V}{\partial y} + \hat{k} \frac{\partial V}{\partial z}\right)$$

$$\vec{F} = -c(\hat{i}yz + \hat{j}xz + \hat{k}xy)$$

$$(b) \quad \vec{F} = -\vec{\nabla}V = -\hat{i}2\alpha x - \hat{j}2\beta y - \hat{k}2\gamma z$$

$$(c) \quad \vec{F} = -\vec{\nabla}V = ce^{-(\alpha x + \beta y + \gamma z)} (\hat{i}\alpha + \hat{j}\beta + \hat{k}\gamma)$$

P.2: Determine which of the following forces are conservative:

$$(a) \vec{F} = \hat{i}x + \hat{j}y + \hat{k}z$$

$$(b) \vec{F} = \hat{i}y - \hat{j}x + \hat{k}z^2$$

$$(c) \vec{F} = \hat{i}y + \hat{j}x + \hat{k}z^3$$

(a)

$$\vec{\nabla} \times \vec{F} = \begin{vmatrix} \hat{i} & \hat{j} & \hat{k} \\ \frac{\partial}{\partial x} & \frac{\partial}{\partial y} & \frac{\partial}{\partial z} \\ x & y & z \end{vmatrix} = 0 \quad \text{conservative}$$

(b)

$$\vec{\nabla} \times \vec{F} = \begin{vmatrix} \hat{i} & \hat{j} & \hat{k} \\ \frac{\partial}{\partial x} & \frac{\partial}{\partial y} & \frac{\partial}{\partial z} \\ y & -x & z^2 \end{vmatrix} = \hat{k}(-1-1) \neq 0 \quad \text{non-conservative}$$

(c)

$$\vec{\nabla} \times \vec{F} = \begin{vmatrix} \hat{i} & \hat{j} & \hat{k} \\ \frac{\partial}{\partial x} & \frac{\partial}{\partial y} & \frac{\partial}{\partial z} \\ y & x & z^3 \end{vmatrix} = \hat{k}(1-1) = 0 \quad \text{conservative}$$

P.3: Find the value of the constant c such that each of the following forces is conservative:

$$(a) \vec{F} = \hat{i}xy + \hat{j}cx^2 + \hat{k}z^3$$

$$(b) \vec{F} = \hat{i}(z/y) + \hat{j}c(xz/y^2) + \hat{k}(x/y)$$

(a)

$$\vec{\nabla} \times \vec{F} = \begin{vmatrix} \hat{i} & \hat{j} & \hat{k} \\ \frac{\partial}{\partial x} & \frac{\partial}{\partial y} & \frac{\partial}{\partial z} \\ xy & cx^2 & z^3 \end{vmatrix} = k(2cx - x)$$

$$2cx - x = 0$$

$$c = \frac{1}{2}$$

(b)

$$\vec{\nabla} \times \vec{F} = \begin{vmatrix} \hat{i} & \hat{j} & \hat{k} \\ \frac{\partial}{\partial x} & \frac{\partial}{\partial y} & \frac{\partial}{\partial z} \\ \frac{z}{y} & \frac{cxz}{y^2} & \frac{x}{y} \end{vmatrix}$$

$$= \hat{i} \left(-\frac{x}{y^2} - \frac{cx}{y^2} \right) + \hat{j} \left(\frac{1}{y} - \frac{1}{y} \right) + \hat{k} \left(\frac{cz}{y^2} + \frac{z}{y^2} \right)$$

$$-\frac{x}{y^2} - \frac{cx}{y^2} = 0$$

$$c = -1$$

$$\text{also } \frac{cz}{y^2} + \frac{z}{y^2} = 0$$

implies that

$$c = -1 \text{ as it must}$$

End of the Lecture

Let Learning Continue

Thank You